



SYSTEMS ENGINEERING MANAGEMENT

**AFTER REQUIREMENTS PROBLEMS,
MANAGEMENT SHORTCOMINGS IN TECHNICAL ...**



5-DAY COURSE

... PROJECTS ARE THE SECOND GREATEST CAUSE OF PROJECT PROBLEMS (IBM). THIS DOES NOT HAVE TO BE!

Great projects come about from great leaders bringing together people having a mix of knowledge, skills, and attitudes well-suited to the task. The leader creates a climate of trust and mutual accountability in pursuit of a shared vision. The leader also manages well, with special concern in engineering projects for managing requirements (scope), complexity, interfaces, configuration, knowledge, data and risk. This five-day Systems Engineering Management training course provides in-depth coverage of how to lead and manage engineering projects to maximize project success, within the project's given constraints. The course establishes sound principles and provides effective methods to successfully manage engineering projects, and for getting the best out of people, individually and in teams.

EXAMPLE PBS/WBS (2)

Legend:

-  Boundary of scope of an Integrated Product Team
-  Cross-team membership
-  Schedule: start and finish
- DSTV - Developmental Space Technology Vehicle
- ECS - Environmental Control System
- FCS - Flight Control System
- FO - Fitout
- I & A - Integration & Assembly
- ILS - Integrated Logistics Support
- N & CS - Navigation & Communication System
- OI - Operating Instructions
- PS - Propulsion System
- PSTV - Production STV
- SD - System Design
- SF - Spaceframe
- SRA - System Requirements Analysis
- STV - Space Technology Vehicle (STV)

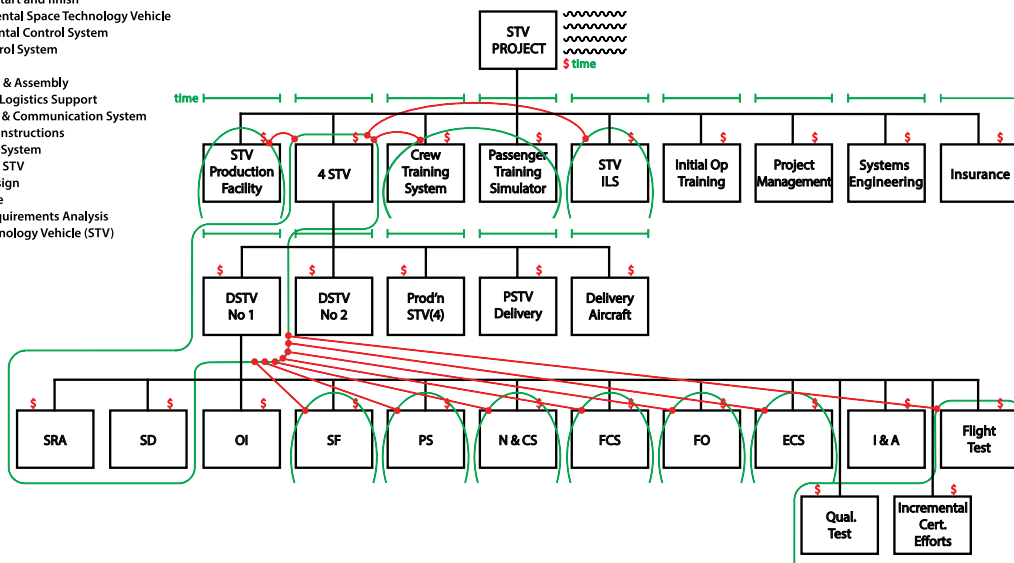

PPI-005163-4
© Copyright Project Performance (Australia) Pty Ltd 2012-2015

"The instructor was unquestionably a master of his material and pitched it at varying levels of expertise so I could get a great deal out of the course."

- participant, Raytheon, USA



1. The Value Proposition for World Class Systems Engineering & Management

The systems engineering management role must understand the value of systems engineering in order to make sound decisions regarding its application. The systems engineering management role will also often need to "sell" systems engineering to other stakeholders in the engineering, such as project management, customers and users. The terms management, project management, engineering management and systems engineering management are all defined in early chapters of the course. These definitions set the scope of systems engineering management as an activity, regardless of who does it.

2. Introduction to Systems Engineering

- the concept of system
- systems thinking
- system life cycle processes
- system life cycle models
- systems-of-systems engineering
- key features of excellence in systems engineering
- key features of excellence in management
- systems engineering principles and concepts
- overall systems engineering process models
- concurrent/simultaneous engineering
- V model, Wedge model, Double-V model, Multiple V model
- understanding the inputs and the outputs
- defining the problem - requirements analysis
- designing the physical solution
- describing the logical solution - functional and state-based design
- effectiveness evaluation and decision-making
- requirements specification writing
- system integration
- verification
- validation
- specialty engineering
- the role of cognitive systems engineering
- development strategies and relationship to planning
- waterfall, incremental, evolutionary, spiral, agile, lean
- concurrent/simultaneous engineering/Integrated Product and Process Development (IPPD)

- engineering for modifications
- *workshop: principles of the engineering of systems*
- Electronic Industries Alliance (EIA)/ Interim Standard (IS) 632, EIA 632, Institution of Electrical and Electronic Engineers (IEEE) 1220, International Standardisation Organisation (ISO)/ International Electrotechnical Commission (IEC) 15288, Capability Maturity Model Integration (CMMI) systems engineering standards
- key engineering artifacts and their roles
 - systems engineering plans
 - operational concept descriptions
 - system requirements specifications
 - software requirements specifications
 - interface requirements specifications
 - verification requirements specifications
 - architectural design descriptions
 - detailed design descriptions
 - test/verification procedures
 - records of test/verification results
 - validation plans/procedures
 - records of validation results
- other potential artifacts
 - integrated logistics support plan
 - feasibility study reports
 - trade-off study reports
 - simulation reports
 - specification tree
- Model-Based Systems Engineering (MBSE) – languages & methods
- systems engineering in a research environment
- software support to systems engineering
- hardware support to systems engineering

3. Relationship of Systems Engineering Management to Other Forms of Management

3.1 Introduction to Management

- the role of management
- basic concepts of management in general
- "The Fifth Discipline" – systems thinking
- value stream mapping

3.2 Introduction to Project Management

- relationship to management in

- general
- the role of project management
- basic concepts of project management
- the PMBOK®
- concepts of lean
- concepts of agile
- project management certifications

3.3 Introduction to Engineering Management

- relationship to project management
- the role of engineering management
- engineering the engineering system

4. Introduction to Systems Engineering Management

- relationship to engineering management
- the role of systems engineering management
- systems engineering within three different business models
 - internal project
 - development under contract
 - product development in anticipation of sales
- tenets of systems engineering management
- systems engineering management and Projects IN Controlled Environments (PRINCE2 TM)
- systems engineering management and Logistics Support Analysis (LSA)
- systems engineering management and contract management
- managing complexity
- managing the development of safety-critical systems
- *workshop: principles in the management of the engineering of systems*

5. Planning the Engineering Effort

- incorporation of risk and opportunity into planning
- major planning artifacts
 - Project (work) Breakdown Structure (PBS/WBS)
 - types of PBS
 - why the PBS is a foundation of effective engineering management
 - rules in preparing a PBS
 - relationship of the PBS to cost accounts
 - relationship of the PBS to work packages
 - PBS (WBS) development pitfalls and pointers

To register visit our website or call our friendly registration team:



PO Box 2385
Ringwood North
Victoria, 3134
Australia



+61 3 9876 7345



enquiries@ppi-int.com



www.ppi-int.com



PROJECT PERFORMANCE
INTERNATIONAL

- **workshop: developing a PBS/WBS**
- systems engineering plans
 - scoping Systems Engineering (SE) - the Systems Engineering Plan (SEP), Systems Engineering Management Plan (SEMP)
 - why prepare a SEP?
 - how a SEP may relate to other plans
 - content of the SEP
 - how the SEP relates to ISO 9001
 - pitfalls in preparing a SEP
- stage plans
- product development plans
- specialty engineering plans, e.g., safety, reliability, producibility
- functional plans, e.g., test plans, system integration plans
- costing the engineering effort
 - cost metrics
 - cost models, e.g., Constructive Systems Engineering Cost Model (COSYSMO), PRICE, SEER
- scheduling the engineering effort
 - event-based planning
- **workshop: SE master schedule**
 - sequencing activities
 - concepts of critical path, and critical path index
- decision analysis and value/cost engineering
- **workshop: decision-making in engineering planning**
- **workshop: constructing an Expected Monetary Value (EMV) decision tree**
- using verification and validation
 - verification and validation terms defined
 - verification requirements
 - methods of verification
 - verification design
 - methods of validation
- technical reviews for verification, validation, assessment and control
 - requirements reviews
 - principles of design review
 - Architectural Design Review (ADR)
 - Detail Design Review (DDR)
 - functional reviews
 - system-wide design reviews
 - Test Readiness Review (TRR)
 - requirements satisfaction audits (FCAs)
 - design description (Build State-Build Standard [BS-BS]) audits (Physical Configuration Audits [PCAs])
 - technical reviews and incremental builds
 - administration of technical reviews
 - customer involvement in technical reviews

- pitfalls in conducting technical reviews
 - planning pitfalls and pointers
- ## 6. Organizing & Conducting the Engineering Effort - Team Processes
- knowledge, skills and attitudes conducive to high performance in the nine systems engineering process areas
 - alternative organizational structures – functional, matrix, project
 - types of teams: teams in general, product development teams, Skunk Works™, process cells, tiger teams, red teams, Interface Control Working Groups (ICWGs), Integrated Product Teams (IPTs).
 - IPT types and related issues
 - characteristics and products of an IPT
 - inside an IPT
 - when to use IPTs
 - **workshop: project structure & IPT membership**
 - team key success factors
 - achieving customer focus
 - challenges to IPT effectiveness
 - IPT formation and start-up
 - IPTs and the PRINCE2™ project management methodology
 - IPTs and data management, configuration management
 - types of IPT
 - team size
 - using product cells
 - using functional cells
 - keys to success
 - staffing the engineering organization
 - relationships to customer and supplier organizations
 - organizational pitfalls and pointers

7. Managing & Leading the Engineering Team

- **Video: Teamwork The Meerkat Way**
- teamwork and teams
 - team performance
 - team development
 - team characteristics
 - team problems
 - leading and coaching
 - interpersonal skills
 - **Video: 5 Dysfunctions of Teams – Patrick Lencioni**
 - **The Pentagon Game – An exercise in team behavior**
- difference between management and leadership
- **Video: The 5 levels of leadership –**

John Maxwell

- team processes and skills
 - innovation
 - problem-solving
 - decision-making
 - implementation
 - communication
- motivation
- emotional intelligence
- Maslow's hierarchy of needs
- personality profiling
- **Video: The Business Case for Strengths – Marcus Buckingham**

8. Requirements Management

- selecting requirements analysis processes
- requirements traceability in requirements analysis
- requirements traceability in design
- traceability from goals
- integration with test or verification traceability – Verification Cross-Reference Index (VCRI)/Verification
- Cross-Reference Matrix (VCRM)/Requirements Test and Evaluation Matrix (RTEM) etc.
- software tools supporting requirements management
- pitfalls and pointers in requirements management

9. Design Management

- selecting design processes
- managing for innovation
- managing design complexity
- avoiding under-engineering
- avoiding over-engineering
- design traceability
- pitfalls and pointers in design management

10. Configuration Management

- what is configuration?
- the concept and types of baseline
- CM standards - EIA, ISO, etc.
- the four fundamental CM activities
- examples of CM implementation
- pitfalls and pointers in configuration management

11. Interface Management

- objectives of interface management
- interface requirements
- interface design
- ensuring interface consistency
- managing evolution of interfaces in complex systems
- organizational aspects of interface management

To register visit our website or call our friendly registration team:



PO Box 2385
Ringwood North
Victoria, 3134
Australia



+61 3 9876 7345



enquiries@ppi-int.com



www.ppi-int.com



PROJECT PERFORMANCE
INTERNATIONAL

- pitfalls and pointers in interface management

12. Management of Engineering Data

- objectives of data management
- data modeling
- tool data exchange
- data management vs configuration management
- pitfalls and pointers in data management

13. Knowledge Management

- objectives of knowledge management
- protection of new knowledge
- lessons learned
- communication of new knowledge
- use of external knowledge – intellectual property
- pitfalls and pointers in knowledge management

14. Engineering Specialty Integration (ESI)

- what makes an engineering specialty special?
- common engineering specialties
- a general approach to ESI
- organizational issues of ESI
- pitfalls & pointers in engineering specialty integration

15. Managing System Integration

- drivers to trouble-free system integration
- system integration planning
- role of integration testing
- responsibility of designers
- diagnosing the causes of problems
- incremental system integration
- integration test beds
- metrics for the balance of work in a system integration phase
- pitfalls and pointers in managing system integration
- *workshop: developing an integration plan*

16. Managing Verification & Validation

- project-wide V&V
- requirements verification methods
- design verification methods
- system/subsystem verification requirements
- system/subsystem verification methods

- system/subsystem verification design
- system/subsystem verification traceability
- pitfalls and pointers in managing V&V

17. Managing the Development of Software-Intensive Systems

- special issues for software-intensive systems
- performance of alternative software development methodologies

18. Engineering Cost & Time Management

- tracking systems engineering costs performance - EVM
- controlling systems engineering costs
- pitfalls and pointers in engineering cost management
- tracking time performance
- controlling systems engineering schedule
- pitfalls and pointers in time management

19. Systems Engineering Performance Management

- technical performance measurement
- technical progress meetings
- earned value management
- integrated performance measurement
- Six-Sigma revisited
- pitfalls and pointers in performance management

20. Risk & Opportunity Management

- the nature of risk
- components of risk
- the nature of opportunity
- the five key activities of risk management
- risk due to requirements
- risk due to technology
- risk due to complexity
- integrating consideration of risk and opportunity into every aspect of systems engineering
- pitfalls and pointers in risk and opportunity management

21. Stakeholder Management

- determining stakeholder interests
- dealing with conflicting interests
- ensuring stakeholders have influence

- keeping stakeholders informed
- reporting to higher-level management

22. Other Techniques for Controlling Outcomes

- qualification
- integrated software support to product life cycle management

23. Release & Deployment Management

- release management
- deployment management
- post-implementation reviews

24. Project Closure

- archiving of engineering data
- maintenance of engineering data

25. Continuous Performance Improvement

- lessons learned
- ISO9000 Quality Management System
- Six-Sigma driving improvement
- CMMI
- pitfalls and pointers in performance improvement

26. Professional Societies & Systems Engineering Education

- International Council on Systems Engineering (INCOSE)
- International Institute of Business Analysis (IIBA)
- national systems engineering societies
- other societies with formal systems engineering interest areas
- systems engineering in undergraduate education
- systems engineering in postgraduate education
- systems engineering certifications
- internal systems engineering education programs

27. In Closing

To register visit our website or call our friendly registration team:



PO Box 2385
Ringwood North
Victoria, 3134
Australia



+61 3 9876 7345



enquiries@ppi-int.com



www.ppi-int.com



PROJECT PERFORMANCE
INTERNATIONAL