

REQUIREMENTS ANALYSIS OVERVIEW

Robert J. Halligan FIE Aust CPEng

2 Parkgate Drive
Ringwood Vic 3134 Australia
email: rhalligan@ppi-int.com

Objectives of Requirements Analysis

The usual criterion for adequacy of a set of requirements is that, if the requirements set is satisfied, the level of risk associated with failing to satisfy the needs of relevant stakeholders is low – typically an expected loss of value of two or three percent, or less.

To this basic criterion can be added the dimension of time. Requirements change with time due to the problem space genuinely changing, and due to “what is possible in technology” triggering perfectly valid new requirements. So, requirements analysis must be an ongoing activity, to a lesser or greater degree.

Techniques of Requirements Analysis

The requirements analysis process used and recommended by the author is illustrated in Figure 1.

REQUIREMENTS ANALYSIS (CAPTURE AND VALIDATION) METHODOLOGY

Legend:

SRA System Requirements Analysis
S/H Stakeholder
DEV Development
OCD Operational Concept Description (CONUSE)
ERA Entity Relationship Attribute
* Perform only if there are initial specified requirements as an input to the analysis.

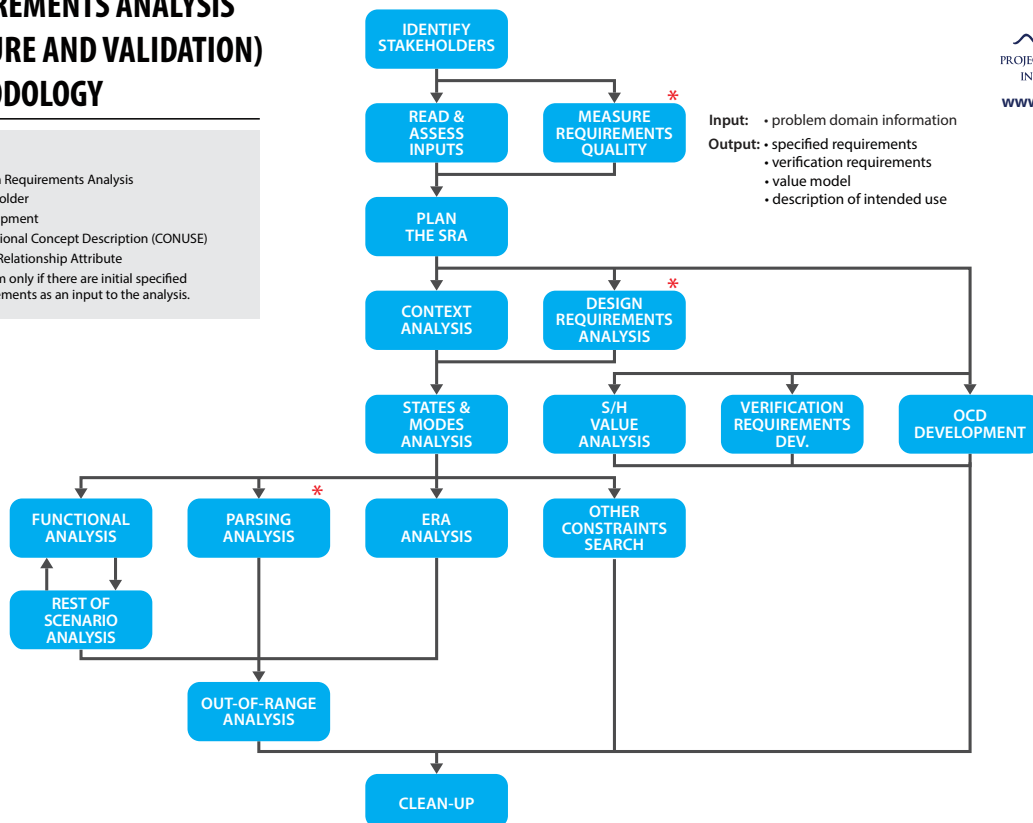

PPI-006248-3
© Copyright Project Performance (Australia) Pty Ltd 1994-2020

Figure 1: An Effective Requirements Analysis Process

The set of techniques which combine to comprise a very effective and efficient requirements analysis methodology is described below:

- Stakeholder Identification.** The objective of stakeholder identification is to identify stakeholders who are potential “owners” of requirements, or who can facilitate effective communication relating to requirements.

These stakeholders are subsequently encouraged to make input into the definition of the requirements, are consulted regarding requirements issues, and are invited to “sign-off” on their subsets of requirements.

- b. **Document Review.** Documents, if any, which contain or relate to intended use, requirements, and goals are examined, with a view to identifying key issues that should be resolved with stakeholders before requirements analysis proceeds too far. This review provides input into the planning for conduct of the requirements analysis.
- c. **Context Flow Analysis.** This analysis tracks the state of the world outside of the system on a whole of life basis, from system cradle to system grave. All requirements of the system originate in these contexts, with one class of exception. Stakeholders are mapped to the contexts, often resulting in the identification of additional stakeholders. The main work product of this analysis is subsequently used to structure analysis work, checks and dialog with stakeholders. See Figure 2.

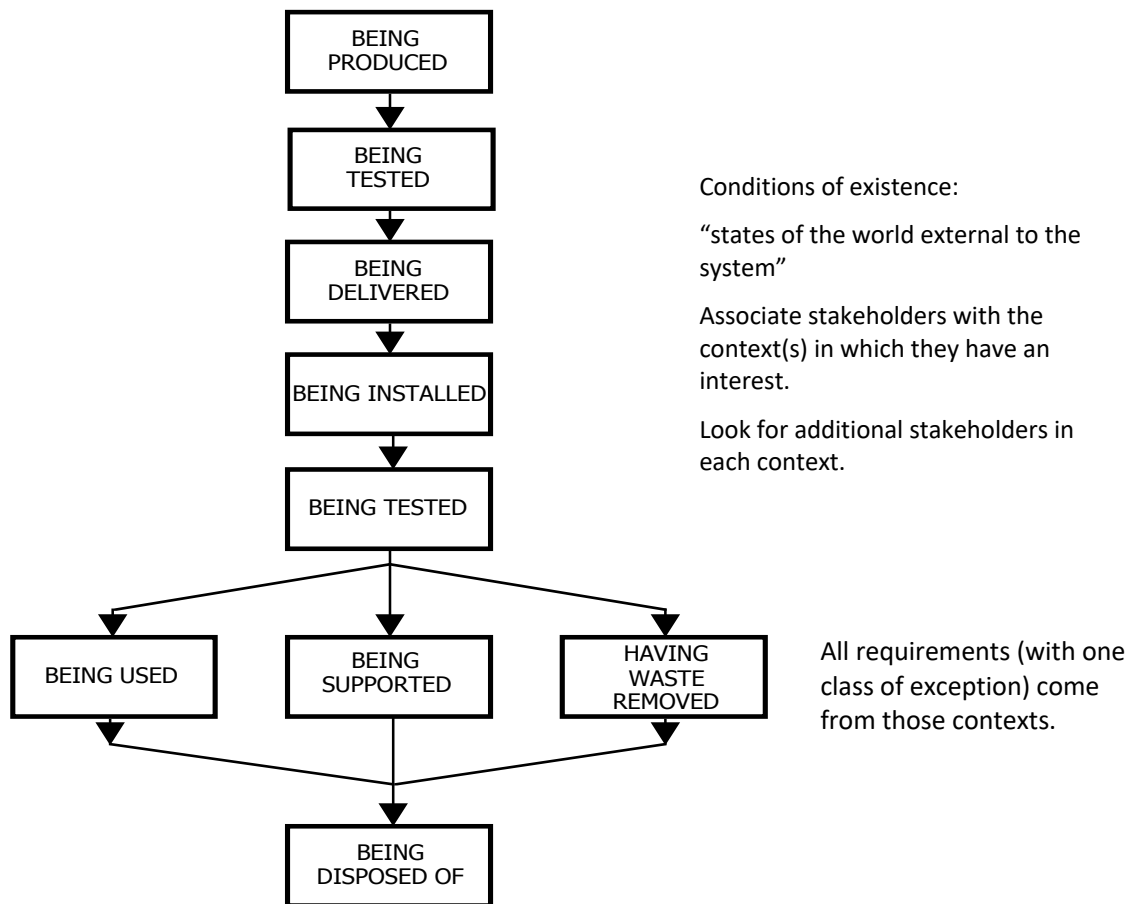

Figure 2: Context Flow Diagram

- d. **Context Analysis.** This analysis identifies/validates mainly external interface requirements. The analysis also contributes to environmental requirements. Context analysis helps identify additional stakeholders in the system: owners of interoperating systems; individuals who will interact with the system; and organizational entities with which the system will interface. Context analysis sets the foundation for subsequent capture and validation of required functionality. See Figure 3.

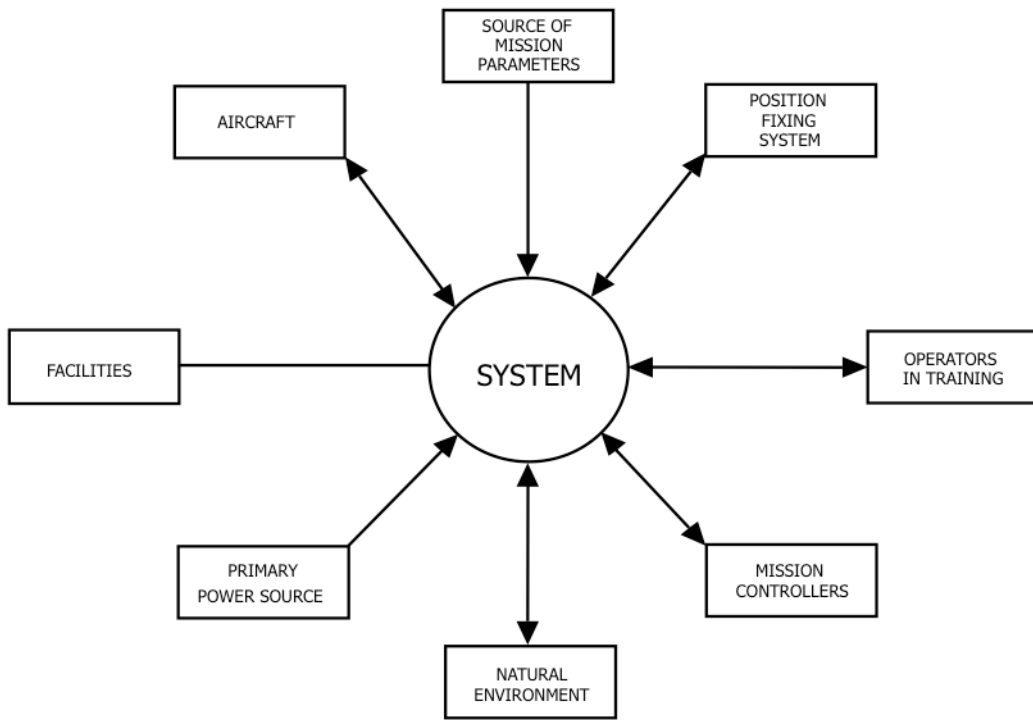
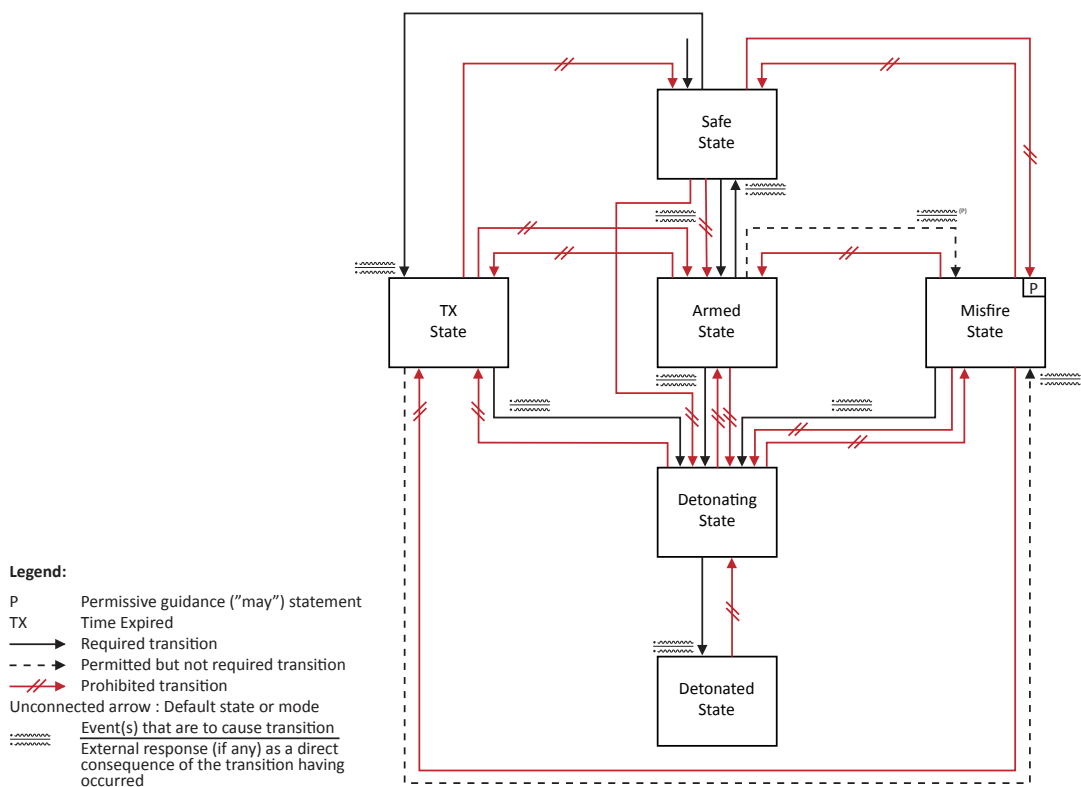

Figure 3: Context Diagram

e. **States and Modes Analysis.** This is a high ROI analysis, which establishes the big-picture dynamics required of the system, expressed in terms of states & modes. States and modes analysis often identifies major requirements issues. The analysis also establishes preconditions for subsequent precise and concise specification of the requirements captured in other analyses. See Figure 4.



PPI-003102-23

Figure 4: States Transition Diagram

- f. **Functional Analysis.** This analysis is conducted within a modeling boundary which encapsulates enough of the problem, including functional aspects of operational scenarios, to capture and validate the required system functional and performance requirements. The result is a set of functional and performance requirements which is sufficiently complete and is at precisely the correct level of abstraction, neither too broad nor at a level of abstraction which directs the implementation of the system, as opposed to capturing the need. Use cases are a basic form of functional analysis; more robust functional modeling techniques can be used for more demanding applications.

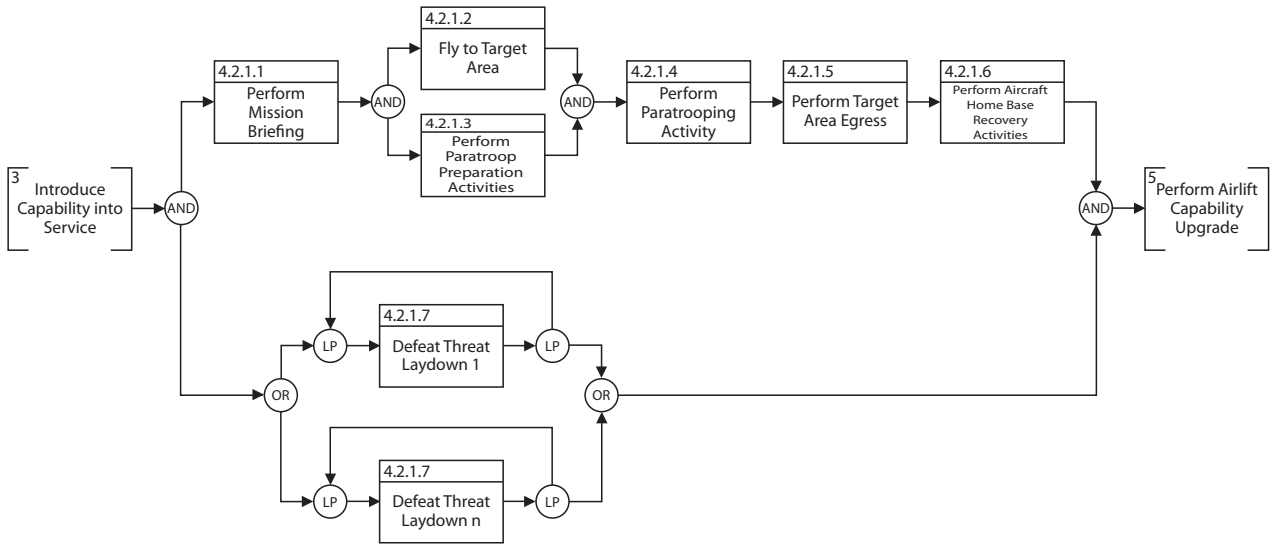

PPI-005642-2

Figure 5: Functional Flow Block Diagram

- g. **Rest of Scenario Analysis.** This analysis, conducted iteratively with functional analysis, identifies/validates environmental requirements, physical requirements, resource requirements and contributes additional content to external interface requirements.
- h. **Entity Relationship Attribute Analysis.** ERA analysis provides input to capture/validation of additional information content of external interface requirements, and some aspects of functional requirements. The analysis is most relevant to data-oriented systems.

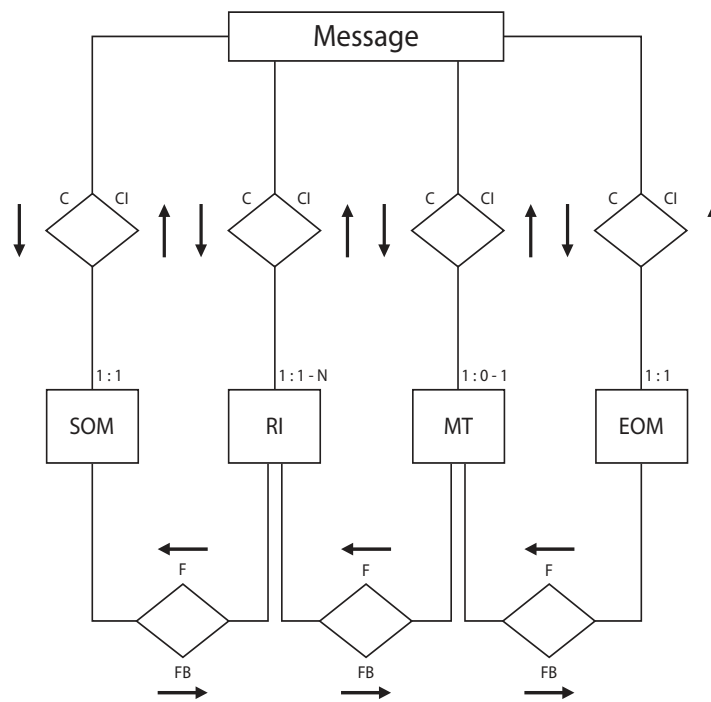

Figure 6: Entity Relationship Attribute Diagram

- i. **Parsing Analysis.** Parsing analysis is a text analysis technique for identification of errors, incompleteness, inconsistency, lack of clarity, ambiguity, lack of verifiability, and infeasibility, in textually stated requirements. The basis of the technique is illustrated in Figure 7:

Element	Text
1. Actor	The Message Switch,
2. Conditions for Action	when in message switching mode, upon receipt of a message,
3. Action	shall switch
4. Constraints of Action 1	
5. Object of Action	that message,
6. Constraints of Action 2	in accordance with IEEE 802.11g, within 10 <u>ms</u> of receipt,
7. Refinement of Object	for messages in ACP128 format having a valid routing indicator,
8. Constraints of Action 3	from the message input port, to a message output port corresponding to the routing indicator in the message,
9. Exceptions to Action	unless the message is of FLASH priority.
10. Other	

PPI-007557-1

Figure 7: Parsing Template

The parsing template also provides an excellent aid to writing good requirements the first time, and for rewriting defective requirements.

- j. **Out-of-Range analysis.** This analysis captures and validates any requirements that relate to defective inputs or outputs or abnormal conditions of use/support/disposal. The requirements from this analysis can make the difference between a system that will be effective in the real world, and a system that could be effective only in the ideal world.
- k. **Other Constraints Search.** This activity looks for requirements which are ordained from on high (such as from statute law, applicable regulations, policy, governing standards, directives).
- l. **Clean-Up.** This activity verifies the refined requirements set, looking for residual defects in the work products of the analysis. Keyword searching is used in combination with specific verification criteria.

Conclusion:

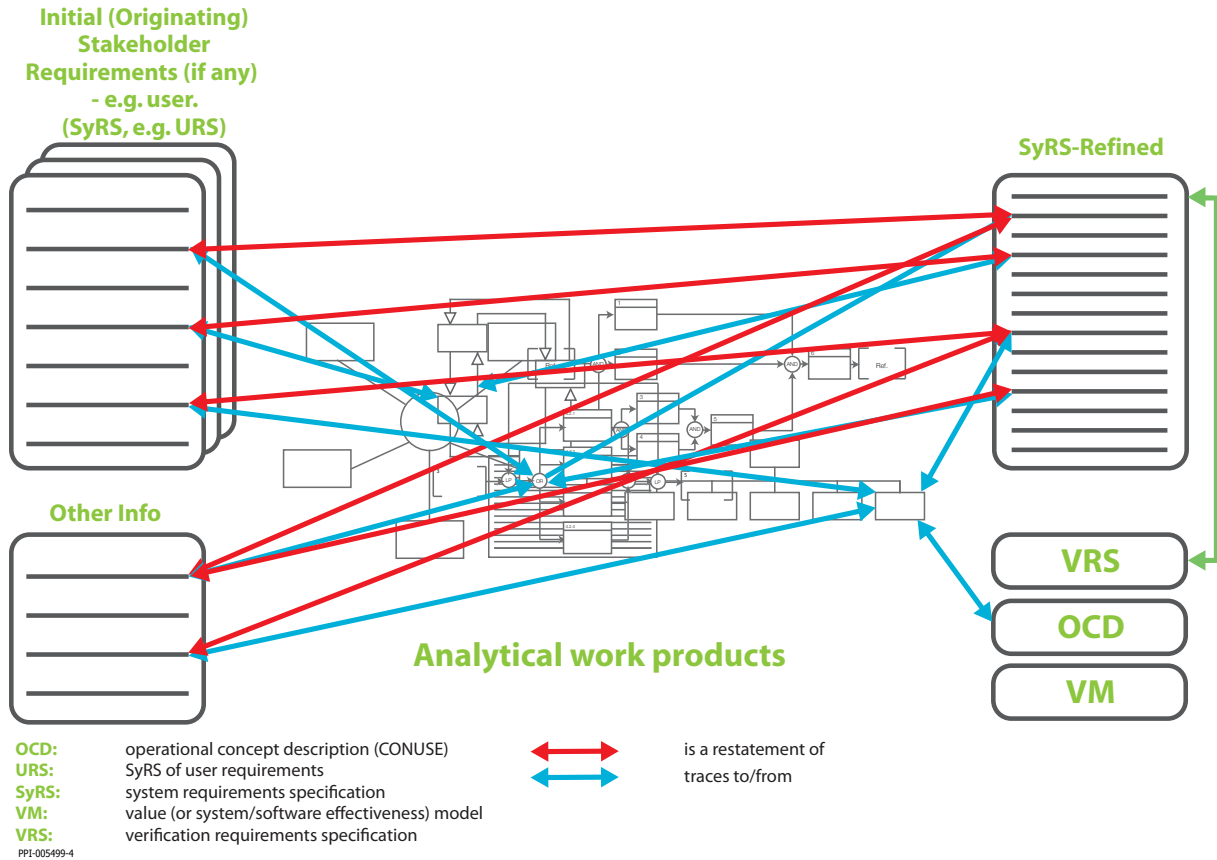

Figure 8: Approach to Requirements Analysis

Methods exist to perform requirements capture and validation both efficiently and very effectively. The methods rely, not on requirements elicitation per se (which is neither efficient nor effective), but on elicitation of responses from stakeholders to specific requirements issues identified mainly through effective analysis of the problem domain.