



# SYSTEMS ENGINEERING NEWSLETTER

PPI SyEN 74 – 21 February 2019

brought to you by

## **Project Performance International (PPI)**

*systems engineering training for project success*

PPI SyEN is an independent free newsletter containing informative reading for the technical project professional, with scores of news and other items summarizing developments in the field, including related industry, month by month. This newsletter and a newsletter archive are also available at [www.ppi-int.com](http://www.ppi-int.com).

Systems engineering can be thought of as the problem-independent, solution technology-independent, life-cycle-oriented principles and methods, based on systems thinking, for defining, performing, and controlling the engineering effort within a technical project. The approach aims to maximize the benefit delivered to the enterprise, as influenced by the needs and values of the other applicable stakeholders.

If you are presently receiving this newsletter from an associate, you may wish to receive the newsletter directly in future by signing up for this free service of PPI, using the form at [www.ppi-int.com](http://www.ppi-int.com). If you do not wish to receive future Systems Engineering Newsletters, please unsubscribe by clicking on the link at the bottom of this email.

We hope that you find this newsletter to be informative and useful. Please tell us what you think. Email us at [syen@ppi-int.info](mailto:syen@ppi-int.info).

The views expressed in externally authored articles are those of the author(s), and not necessarily those of PPI or its professional staff.

# IN THIS EDITION

## 1. Quotations to Open On

[Read More...](#)

## 2. Feature Article

- 2.1 Bridging the Gap between Systems Engineering and Program Management via a Risk Aware Framework *by Scott Stribrny*

[Read More...](#)

## 3. Additional Articles

- 3.1 Requirements Analysis Overview *by Robert Halligan*
- 3.2 Integrating Program Management and Systems Engineering *by Randall Iliff*

[Read More...](#)

## 4. Systems Engineering News

- 4.1 INCOSE International Workshop 2019 Working Group Results
- 4.2 INCOSE is Forming a Telecommunications Working Group
- 4.3 Upcoming INCOSE Paper Certification Exam in Orlando, Florida
- 4.4 INCOSE Webinar: Machine Assisted Requirements Inspection and Evaluation (M.A.R.IN.E)
- 4.5 INCOSE Webinar: Encouraging Broader Engagement and Collaboration across the Enterprise using MBSE Tools
- 4.6 Space and Naval Warfare Systems Command Updates Dictionary for Interoperability
- 4.7 International Institute of Business Analysis (IIBA) Introduces New Agile Extension to BABOK Guide
- 4.8 Systems Engineering Company Complements and Expands Zuken Solutions
- 4.9 INCOSE is Looking for New Members to Join TechOps
- 4.10 INCOSE Announces Systems Engineering Mentors/Mentees Program
- 4.11 Annual GfSE Workshop
- 4.12 Presentation: V-Model Approach to K-12 Learning

[Read More...](#)

## **5. Featured Organizations**

5.1 Systems Society of India

5.2 Waters Foundation for Systems Thinking

[Read More...](#)

## **6. News on Software Tools Supporting Systems Engineering**

6.1 Phoenix Integration and PTC Introduce ModelCenter MBSE for PTC Integrity Modeler

[Read More...](#)

## **7. Systems Engineering Publications**

7.1 Feature Engineering Made Easy

7.2 INCOSE SoS Primer

7.3 INCOSE Systems Engineering Competency Framework

7.4 Systems Engineering for Projects: Achieving Positive Outcomes in a Complex World (Best Practices in Portfolio, Program, and Project Management)

7.5 Effective Model-Based Systems Engineering

[Read More...](#)

## **8. Education and Academia**

8.1 Portland State University Department of Engineering and Technology Management (ETM)  
Portland, Oregon (USA)

8.2 Electronic Systems Engineering (ESE) at the University of Regina – Regina, Saskatchewan  
Canada

8.3 Tenure-Track Faculty Positions – Stevens Institute of Technology

[Read More...](#)

## **9. Some Systems Engineering-Relevant Websites**

[Read More...](#)

## **10. Standards and Guides**

10.1 ISO/PAS 19450:2015 Object-Process Methodology (OPM)

10.2 Technology Management Training Manual – The International Centre for Science and High Technology

[Read More...](#)

## **11. Some Definitions to Close On**

11.1 Framework

11.2 Complex

11.2 Risk

[Read More...](#)

## **12. Conferences and Meetings**

12.1 The featured event for this edition is: SERC Capstone Marketplace Summit

[Read More...](#)

## **13. PPI and CTI News**

[Read More...](#)

## **14. PPI and CTI Events**

[Read More...](#)

## **15. PPI Upcoming Participation in Professional Conferences**

[Read More...](#)

---

# 1. QUOTATIONS TO OPEN ON

---

“Objectives drive principles. Principles drive process. Process drives software tools.”

*Robert John Halligan*

“The essence of an engineering project is that of a socio-technical endeavor.”

*Ian Hirst, Principal Consultant Software Engineering, PPI*

“If you don’t have time to do it right, when will you have time to do it over?”

*Albert Einstein*

---

## 2. FEATURE ARTICLE

---

### 2.1 Bridging the Gap between Systems Engineering and Program Management via a Risk-Aware Framework

*by*

Scott Stribrny

President and Managing Director  
Group Atlantic, Inc., Oakbrook Terrace, IL USA

Email: [scott.stibrny@groupatlantic.com](mailto:scott.stibrny@groupatlantic.com)

#### **Abstract**

Complex engineering systems are prone to schedule slips, budget overruns, and a variety of challenges that compromise delivered value. These challenges are a sign of failure on the part of both management and technical roles, but can be overcome through a Risk Aware Framework to integrate the roles into a cohesive systemic approach in order to deliver high-value business outcomes.

This article describes how your organization can become more effective, more efficient, more responsive, and enjoy better business outcomes by bridging the gap between Systems Engineering and Program Management via a Risk Aware Framework. Beginning with an overview of key concepts, the article details the challenges faced by Systems Engineering and Program Management practitioners every day. The practical framework that follows describes how a principled process can be integrated successfully to streamline project workflow. A case study details how a real-world company successfully implemented

a risk framework to improve cost and schedule performance which can also ensure the success of your organization's own strategy.

This article describes a proven framework to:

- Overcome challenges and improve cost, schedule, and business performance
- Assess current capabilities and build to the level your organization needs
- Manage risk throughout all stages of a Project Life Cycle
- Deploy best practices for teams and systems.

## Introduction

How's this for a system engineering truism: "The best system engineers possess the superior judgment to avoid situations requiring their superior skills to survive." While arguably truer than a whole wealth of truisms, it doesn't provide much guidance in our quest to become one of those wiser and more-capable system engineers, especially when we find ourselves in a position of leadership. Which raises an obvious question: How does one develop such profound judgment?

Regardless of our degree of skill and experience, the trick to safely nudging the envelope comes in knowing as much about what we don't know as what we think we know and weighing those factors wisely before we venture forth. And the process of weighing those elements before making the call is a process known as "risk management".

This is an era in which risk-taking is rewarded, leaving companies that run away from risk as plunder to be divided up by the others. Risk is inherent in all activities. It is a normal condition of existence. Every day, companies are exposed to various types of risk. They can be connected to property, liability of third parties, staff or decisions; risk is the usual companion in every business and with direct influence on result. But what is a useful way to think about risks and risk-taking in today's environment?

Risk is the potential of loss resulting from a given action, activity and/or inaction. Usually we have a choice and have an influence on the outcome. Exact definition of risk is given within the ISO/IEEE Standard 16085:2006 Standard for Software Engineering – System Life Cycle Processes – Risk Management.<sup>1</sup>

Risk is not a problem. It is an understanding of the level of threat due to potential problems. A problem is a consequence that has already occurred. Risk is defined by two characteristics of a possible negative future event: probability of occurrence (whether something will happen) and consequences of occurrence (how catastrophic if it happens). If the probability of occurrence is not known, then one has uncertainty and the risk is undefined.

The computerization of the workplace and the levels of IT dependency that now exist means the risks associated with the failure of IT systems are one of the most potent sources of operational risk within any organization. Systems engineering management related risks could be related to the system products or to the process of developing the system.<sup>2</sup> Risk management is quickly changing the environment, for it

---

<sup>1</sup> Available at <https://standards.ieee.org/standard/16085-2006.html>.

<sup>2</sup> Byrd and Cothorn, *Introduction to Risk Analysis: A Systematic Approach to Science-Based Decision-Making*.

contributes to reaching strategic advantages of a company. Inadequate attention to risk, especially at the early stages of a systems engineering project, is often the reason for cost overruns, schedule delays, and poor technical performance.

### **Consider the Future of Your Present Decision Process**

The purpose of risk management is to make decisions, not to admire the risks. No behavior goes more to the core or soul of a company than how the company goes about making decisions.

Making the right decision means performing risk analysis. Risk analysis is the systematic use of available information to determine how often specified events may occur and the magnitude of their consequences. The goal of any of these methods is to help the decision-maker choose a course of action, given a better understanding of the possible outcomes that could occur. By exploring the full space of possible outcomes for a given situation, a good risk analysis can both identify pitfalls and uncover new opportunities. Risk analysis can be performed qualitatively or quantitatively. Qualitative risk analysis generally involves assessing a situation by instinct or feeling and is characterized by descriptive statements. Quantitative risk analysis attempts to assign numeric values to risks, either by using empirical data or by quantifying qualitative assessments.

### **Three Essential Elements for Success**

Providing effective risk management for an organization requires a change in language and attitude towards risk and its link to decision-making. This involves behavioral changes at all organization levels and requires at least three elements:

- A repeatable **process** with defined steps and artifacts supported by applicable methods and tools.
- Widespread access to adequate **knowledge** sources to support the process.
- Functional **behavior** including human interactions, motivators, perceptions, communication, decision-making processes, and risk tolerance.

These are not independent elements; there are strong interactions that must be accounted for in implementing and sustaining risk aware management. Process and knowledge sources, while necessary, cannot by themselves change behavior. The last element is the key and yet it has received little attention. Although change management is a discipline in its own right, there are special considerations for risk management.

Providing effective risk management practice in an organization requires that the role of all three - process, knowledge, and behavior -- are understood. However, it is the issues involving functional behavior that will determine whether a risk management practice can be successfully sustained.

### **Case Study**

One company that has thrived with risk is Rockwell Collins<sup>3</sup> (now Collins Aerospace). An independent audit revealed that due to risk management practice, Collins achieved double digit improvement in Cost Performance Index and Schedule Performance Index. Enterprise Risk Management (ERM) at Rockwell

---

<sup>3</sup> <https://www.rockwellcollins.com>

Collins comprises two dominant threads that encircle a central decision process, as well as each other, forming a strong organizational risk culture. The central decision process at Collins is a phase gate model that covers the entire lifecycle of a business opportunity. The decision process directs a compelling set of business questions at key points in the lifecycle of each endeavor. It ensures productive interrogation and structuring of the company's discretionary investments. As an organization, Rockwell Collins minimizes surprises, provides relevant, objective, and timely information to decision-makers, and focuses on asking the right questions. Seven key questions that are regularly and rigorously answered are:

1. What are today's risks - are they higher or lower than before?
2. Are the risks likely to get higher or lower in the future?
3. What is being done to reduce risks, to monitor risks and to prevent risks in the future?
4. Who is responsible for the aversion measures - who can I call if things are not correct?
5. How will I know the aversion measures are being put into place?
6. What is the timetable for the aversion measures?
7. How and what should I communicate concerning risk internally, to suppliers, and to the customer?

Focused through the phase-gate decision process, the complementary decision processes of management of risk and risk management allow Collins to address risk in a systemic, multidisciplinary manner that weaves business strategy, finance, and program and project management into a comprehensive and unified whole.

Communication of risks is one the most challenging tasks in risk management. Project team members who are in a position to recognize many of the risks typically include system engineers working on the project. For a variety of reasons, these people may not be willing to communicate the risk. Collins' success is in part to creating an environment that generates information pull. System engineers and their managers must understand that merely identifying a risk and placing it into a risk register does not mean that it will be appropriately addressed.

At Collins, one means of creating information pull is to condition people at all levels to ask questions that elicit risk causes and characteristics. For example, my long-time associate at Rockwell, the late Art Gemmer, described<sup>4</sup> how his organization coached managers to consider certain questions in response to cues, some of which are listed in the table (From "Risk Management: Moving Beyond Process" by Art Gemmer in *IEEE Computer*, May 1997) below.

---

<sup>4</sup> Gemmer, Art, "Risk Management: Moving Beyond Process," *IEEE Computer*, May 1997.



If the team says...	Management should ask...
“There’s an issue here”	Is the issue an opportunity, a risk or a problem? What uncertainty surrounds the issue? What choices do we have for dealing with it? Are they proactive or reactive? How does the outcome affect expectations? If it’s an opportunity, what risks are associated with pursuing it?
“Here are our risks”	Which risks do you want us to hear? Do you need our help with any of these? Do we have consensus on the risk’s characteristics? Do we have consensus on the actions to be taken?
“We’re taking a calculated risk” or “We assume that...”	What calculations led you to this approach? What are sources of uncertainty? Which are related to time? Which are related to control? Which are related to information? How can they be minimized? What biases may be present in our perception of risk? What will we do if the risk occurs? What evidence, if found, would affect the validity of the assumption?

### Access to Adequate Knowledge Sources for Four Types of Risk

Successfully answering key risk aware management questions demands a widespread access to adequate knowledge sources to fuel the risk aware process. It involves four types of risks: **Programmatic, Organizational, Economic and Technical (POET)**. Classification of risks is helpful in order to group those with similar risk characteristics, and is fundamental to any engineering system in order to evaluate them.

Product risks include both end product risks that relate to the basic performance and cost of the system and enabling products that relate to the products that produce, maintain, support, test, train, operate, and dispose of the system. Risks relating to the management of the development effort can be technical management risk or risk caused by external influences. Risks dealing with internal technical management include those associated with schedules, resources, work flow, on time deliverables, availability of appropriate personnel, potential bottlenecks, critical path operations, and the like. Risks dealing with external influences include resource availability, higher authority delegation, level of program visibility, regulatory requirements, and the like. Descriptions of each of the four POET risk types is given below:

1. **Programmatic Risk:** This is the risk that a major change initiative could fail or the benefits expected of it might not materialize. With an increasing use of projects and programs intended to drive through change within organizations, this type of risk is often closely associated with strategic risk, as failure can have significant impacts on the organization. Moreover, with the increasing complexity of organizations, managing this type of risk is an essential skill.

Drivers to programmatic risk include:

- project purpose and/or need is poorly defined
- project scope definition is poor or incomplete
- project scope, schedule, objectives, cost and deliverables are not clearly defined or understood
- lack of control exists concerning staff priorities
- too many projects

- consultant or contractor delays
- estimating and/or scheduling errors
- unplanned work that must be accommodated
- communication breakdown with project team
- pressure to deliver project on an accelerated schedule
- lack of coordination/communication
- lack of upper management support
- change in key staffing throughout the project
- inexperienced workforce/inadequate staff/resource availability
- local agency issues
- public awareness/support, and agreements.

## 2. **Organizational Risk:**

Drivers to organizational risk include:

- inexperienced staff assigned to project
- losing critical staff at crucial point of the project
- insufficient time to plan
- unanticipated project manager workload
- internal “red tape” causes delay getting approvals and in making decisions
- functional units not available
- overloaded staff and resources
- lack of understanding of complex internal funding procedures
- not enough time to plan
- change of priorities on existing program
- new priority project inserted into program
- inconsistent cost, time, scope and quality objectives.

**3. Economic Risk:** This includes those risks that can affect the business in terms of its general financial viability, such as risks associated with the market in which the organization operates (market risk), as well as the ability to finance growth through loans (credit risk). These risks are generally well understood, with a large number of financial instruments and techniques available to the risk manager.

**4. Technical Risk:** This is different from operational risk in that it is associated with bringing new technology products to market and introducing new technology into the organizational setting, both of which are high risk ventures.<sup>5</sup>

Drivers to technical risk include:

- incomplete design
- incomplete and/or errors in environmental analysis
- unexpected geotechnical issues
- change requests because of errors
- inaccurate assumptions on technical issues in planning stage
- delays and/or errors in surveys
- errors with materials/geotechnical/foundation
- incomplete and/or errors in structural designs
- incomplete and/or errors in hazardous waste site analysis
- emerging need for design exceptions
- consultant design not being up to department standards
- context-sensitive solutions applied without considering difference in context
- fact sheet requirements (exceptions to standards).

#### **Risk Management Framework (A repeatable process with defined steps)**

Figure 1 provided below is a widely recognized risk management framework that depicts the different activities involved in the risk-aware management associated with system engineering. The framework represents a dynamic, continuous, and highly-iterative process; the arrows show the logical flow of information between the activities. From this framework, a project may evolve a risk management process that best fits its system engineering project management structure.

---

<sup>5</sup> Bristow, Michele, Liping Fang, and Keith W. Hipel, "System of Systems Engineering and Risk Management of Extreme Events: Concepts and Case Study".

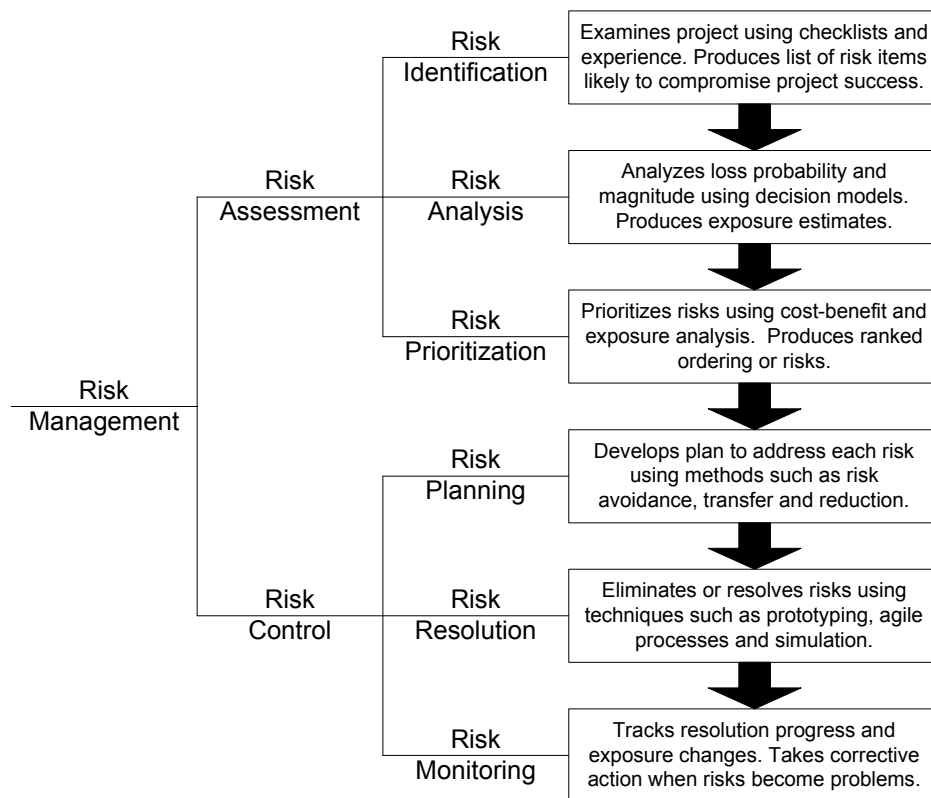

Figure 1: Risk management framework depicting activities in a risk-aware system engineering Environment

### Dis-functional Behavior: Risk Arrogance

*Francis Bacon is quoted as saying, "Man prefers to believe what he prefers to be true."*

Managers in organizations tend to think that effective risk management will result from having a repeatable process and widespread access to adequate information about risk management. However, "Following a repeatable process may mean we are just systematically managing risk poorly. Likewise, having adequate sources of knowledge doesn't necessarily motivate people to use them correctly."<sup>6</sup>

Managers in companies who seem to understand the necessity of risk-taking are sometimes prone to the following strange behavior: They try to emphasize positive thinking by ignoring the possible unfortunate consequences of the risk they're taking. This is an extreme variant of the can-do attitude. After all, risk awareness involves at least a bit of can't do thinking, they reason, so it can't be good. In order to stay positive, they steadfastly refuse to consider much of the downside. If there are things that could go wrong, that would make your project a total fiasco, for example, they would just have you not think about those things at all.

Denial is a major reason risk management is not usually done as part of project management: "software project success is based upon minimizing the thought of possible failure."<sup>7</sup> Typical organizations are

<sup>6</sup> Gemmer, Art, "Risk Management: Moving Beyond Process," IEEE Computer, May 1997.

<sup>7</sup> Charette, R., Software Engineering Risk Analysis and Management, McGraw-Hill Company.

focused on the success of a project. Owning up to risks is all too often considered defeatism. The problems created by a “can-do” attitude, paradoxically, increase with the exposure and difficulty of a risk.

It’s not only managers who are subject to such hubris. If you’re a younger and less experienced systems engineer, not only might you be unaware of the risks confronting you, but you may truly believe that any such risks that might emerge can be overcome, because *you’re real smart and you’re willing to work real hard*.

Many organizations in fact foster such attitudes as part of having a can-do ethic. Risk averse and arrogant attitudes lead to systems engineering dominated by crisis management and heroics. The organizational incentives are often structured to reward heroics and “can-do” employees. This positive reinforcement further ingrains these destructive attitudes.

Among aviators there is a saying, “There are old pilots and there are bold pilots, but there are no old bold pilots.” Few experienced system engineers are so foolish as to ignore all risk. When people ignore risk, they do it selectively. The way it typically works is, they take elaborate care to list, analyze, and monitor all the minor risks (the ones they can hope to counteract through managerial action) and only ignore the really ugly ones. Tip: “Go ugly early.”

### **Create a New Functional Behavior**

Here’s a credo that describes the risk-related functional behaviors for which we should strive.<sup>8</sup>

- **Manage risk as an asset.** We choose the types of risks we face to match our business needs. We understand and anticipate our customers’ and competition’s opportunities and risks as well as their problems. We manage this knowledge as a strategic competitive advantage.
- **Treat decision making as a skill.** Decision-making is a critical skill that we teach, practice, and constantly strive to improve.
- **Create a pull for risk information.** We ask the right questions to obtain risk formation. We actively seek it. We conduct meaningful discussions of our risks and act on the results.
- **Seek diversity in perspectives and information sources.** We seek information from the political, cultural, economic, environmental, and technical realms. We involve multiple disciplines. We listen for and learn from divergent viewpoints.<sup>9</sup>
- **Minimize uncertainty in time, control, and information.** We systematically search for uncertainty wherever it may be. This search is the heart of a learning organization.
- **Recognize and minimize bias in perceiving risk.** We make decisions based on sound information that is derived from an adequate analysis of the situation.
- **Plan for multiple futures.** We plan for the best case, worst case, and several most likely scenarios.

---

<sup>8</sup> Charette, Robert. “On Becoming a Risk Entrepreneur.” Cutter IT Journal, Vol. 8, No. 3, March 1995, pp. 10-15.

<sup>9</sup> See Jim Armstrong, “Divergent Thinking in Systems Engineering Practice: Is There a Shortfall?” for recent thinking concerning divergent thinking.

- **Be proactive.** We act before things go wrong. We attack root causes. We look for and address systemic risks.
- **Make timely, well-informed decisions and commitments.** The purpose of risk management is to make decisions, not just identify risks. We understand when decisions must be made. We manage the risks and understand the chances of success before we make commitments.
- **Reward those who identify and manage risks early, even if the risks become problems.** Even prudent risk takers will realize some problems. Our heroes are not just those people who solve problems, but also those who intelligently avoid them.

### **Be Prepared to Slay a Sacred Cow**

A huge obstacle to risk aware management is organizational memory. The memory of “how we’ve always done things around here” is an ad hoc truth that substitutes for “doing things the right way around here.” The root is fear. People don’t want to make mistakes, and the best way to avoid making a mistake is to continue doing things exactly as they’ve always been done.

Organizations get trapped in a kind of circular logic: “We do what we do because it’s the best thing to do. And it’s the best thing to do because it’s what we’ve always done.” Unfortunately, this is a comforting fantasy for too many. What you end up with are sacred cows — things that you take for granted; pro forma (“tick in the box”) risk management processes that you have come to believe will help you get things done. In reality, all they do is get in the way of getting things done. You must be prepared to slay a sacred cow. The greatest challenge may be finding the courage to candidly answer the question, “Are we ready to hear the ruthless truth about the risks of our system engineering decisions?”

The truth is that significant, lasting performance improvement in risk aware management may require a courageous change in your organizational culture even before driving ongoing, institution-wide initiatives to optimize performance. Progress will occur in your organization when (and only when) a positive vision for the future accompanied by dissatisfaction with the status quo is greater than the natural human resistance to change (and resistance to the truth). Be prepared to challenge yourself to commit to evidence-based risk aware management as a way of organizational life.

### **Conclusion**

Risk aware management is a vital part of successful systems engineering and project management. Although most systems engineering managers know what to do, sometimes they just don’t do it. Some of the factors that contribute to this behavior include deficient systems engineering processes, failure to adopt a risk aware management process, risk-averse or reckless attitudes, and failure to consider organizational context.

While there are many possible steps to improve risk management in an organization, some of those that appear to have the most potential for success include training managers to elicit risk information through checklists and improved communication methods, aligning rewards and incentives with risk management activities, examining risks in the context of the organization, and managing risks across an organization. These techniques are not typically part of risk management processes. And therein lies perhaps the most important lesson: Risk Aware Management is more than a process; it requires the right information and the right behavior to bridge the gap between Systems Engineering and Project Management.

## References

Armstrong, Jim, "Divergent Thinking in Systems Engineering Practice: Is There a Shortfall?" *Project Performance International Systems Engineering Newsletter* (PPI SyEN), Issue 71, November 2018. Available at <https://www.ppi-int.com/ppisyen71/>.

Bristow Michele, Liping Fang, and Keith W. Hipel, "System of Systems Engineering and Risk Management of Extreme Events: Concepts and Case Study". *Risk Analysis*, [Volume 32, Issue 11](#), November 2012, pp. 1935-1955. Available at <https://onlinelibrary.wiley.com/doi/abs/10.1111/j.1539-6924.2012.01867.x>.

Charette, Robert, "On Becoming a Risk Entrepreneur". *Cutter Business Technology Journal*, Vol. 8, No. 3, March 1995, pp. 10-15.

Byrd, Daniel M. III and C. Richard Cothorn, *Introduction to Risk Analysis: A Systematic Approach to Science-Based Decision-Making*. Lanham, Maryland USA: The Scarecrow Press, a wholly-owned subsidiary of the Rowman & Littlefield Publishing Group. Available at Amazon ([https://www.amazon.com/Introduction-Risk-Analysis-Systematic-Science-Based/dp/0865876967/ref=sr\\_1\\_1?s=books&ie=UTF8&qid=1546982910&sr=1-1&keywords=Introduction+to+Risk+Analysis%3A+A+Systematic+Approach+to+Science-Based](https://www.amazon.com/Introduction-Risk-Analysis-Systematic-Science-Based/dp/0865876967/ref=sr_1_1?s=books&ie=UTF8&qid=1546982910&sr=1-1&keywords=Introduction+to+Risk+Analysis%3A+A+Systematic+Approach+to+Science-Based)), 2000.

Charette, Robert. *Software Engineering Risk Analysis and Management*. McGraw-Hill Company.

Collins Aerospace, <https://www.rockwellcollins.com>

Gemmer Art. "Risk Management: Moving Beyond Process", *IEEE Computer* May 1997 (Vol 30, Issue 5), pp. 33-43. Available at <https://www.computer.org/csdl/mags/co/1997/05/r5033-abs.html>.

ISO/IEEE Standard 16085:2006. Standard for Software Engineering – Software Life Cycle Processes – Risk Management. Available at <https://standards.ieee.org/standard/16085-2006.html>.

## About the Author



Scott Stribny brings nearly 40 years of experience in software, systems, and management to his client engagements and his Loyola Executive Education courses. An internationally acknowledged authority in project management, information systems/technology, and the use of agile approaches to delivering exceptional quality and lasting value, Scott is interested in the intersections of business, technology, and organizational risks.

Beginning a corporate career with a start-up firm that went from zero to 100 million dollars in just five years, Scott moved on to a Fortune 50 conglomerate where he worked with industry leading engineers, scientists, and the executive suite. Scott ascended to management and was responsible for the development of groundbreaking products and services where he applied best practices in project management and organizational change. His accumulated management experience ranges across many industries, including aerospace, telecommunications, finance, insurance, retail, information services, and manufacturing.

Scott is president, co-founder, and managing director of Group Atlantic, Inc.; a senior consultant in the business technologies strategies practice for IT research company the Cutter Consortium; and a thought leader at the IT Metrics and Productivity Institute. His courses on leadership development, high-performance teams, requirements definition, risk management, and project estimating are well known for their innovation and practical applicability.

Scott is widely published on the subjects of risk management and project/program management and is a frequent keynote speaker at conferences and company events. He is known for his practical knowledge and content, and refreshing and engaging delivery.

---

## 3. ARTICLE

---

### 3.1 Requirements Analysis Overview

*by*

Robert J. Halligan FIE Aust CPEng IntPE(Aus)

Managing Director, Project Performance International

Email: [rhalligan@ppi-int.com](mailto:rhalligan@ppi-int.com)

**Copyright: Robert J. Halligan, 2019**

#### **Objectives of Requirements Analysis**

The usual criterion for adequacy of a set of requirements is that, if the requirements set is satisfied, the level of risk associated with failing to satisfy the needs of relevant stakeholders is low – typically an expected loss of value of two or three percent, or less.

To this basic criterion can be added the dimension of time. Requirements change with time due to the problem space genuinely changing, and due to “what is possible in technology” triggering perfectly valid new requirements. So, requirements analysis must be an ongoing activity, to a lesser or greater degree.

#### **Techniques of Requirements Analysis**

The requirements analysis process used and recommended by the author is illustrated in Figure 1.

The set of techniques which combine to comprise a very effective and efficient requirements analysis methodology is described below:

- a. **Stakeholder Identification.** The objective of stakeholder identification is to identify stakeholders who are potential “owners” of requirements, or who can facilitate effective communication relating to requirements. These stakeholders are subsequently encouraged to make input into the definition of the requirements, are consulted regarding requirements issues, and are invited to “sign-off” on their subsets of requirements.



- b. **Document Review.** Documents, if any, which contain or relate to intended use, requirements, and goals are examined, with a view to identifying key issues that should be resolved with stakeholders before requirements analysis proceeds too far. This review provides input into the planning for conduct of the requirements analysis.

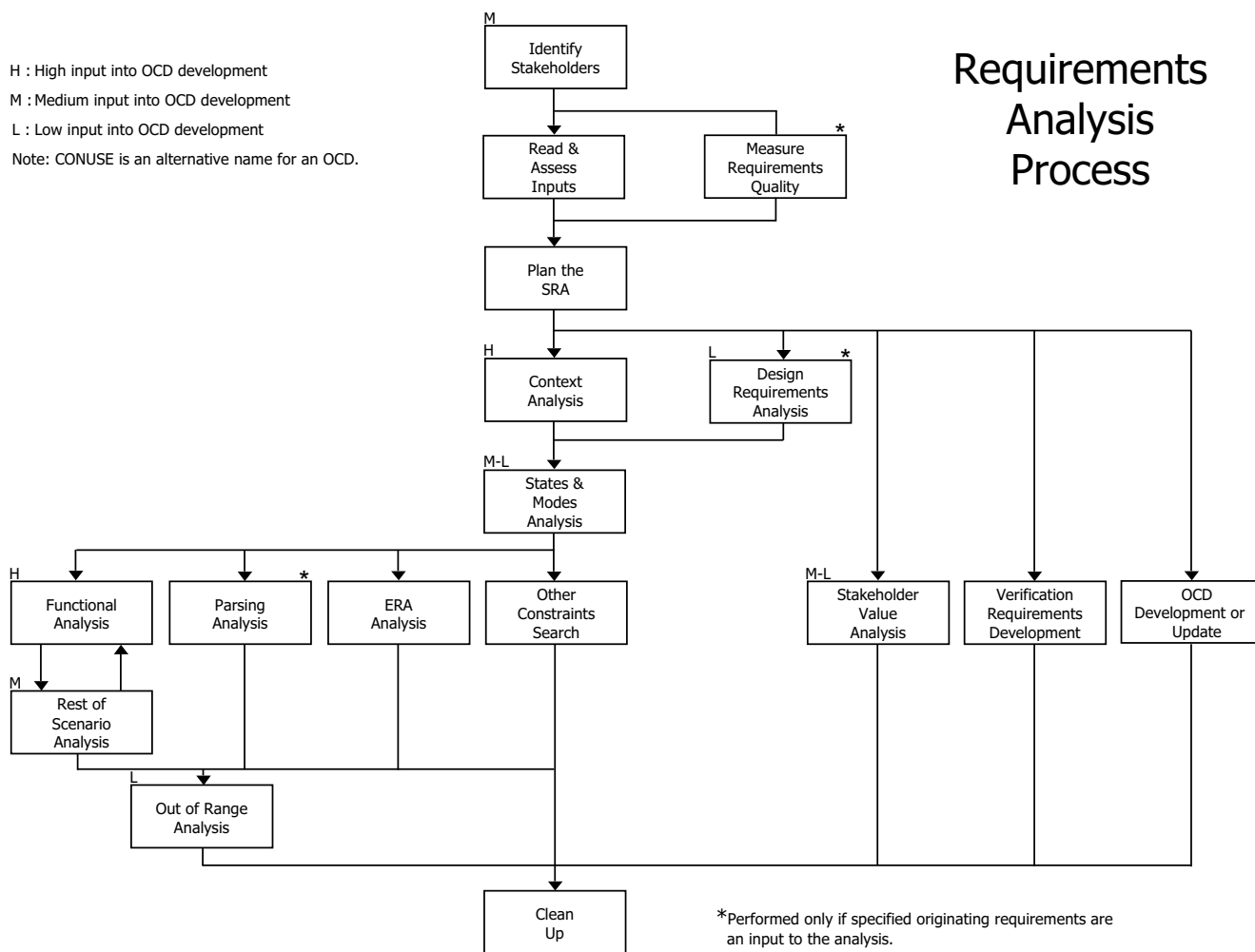

PPI-005566-10

Figure 1: An Effective Requirements Analysis Process

- c. **Context Flow Analysis.** This analysis tracks the state of the world outside of the system on a whole of life basis, from system cradle to system grave. All requirements of the system originate in these contexts, with one class of exception. Stakeholders are mapped to the contexts, often resulting in the identification of additional stakeholders. The main work product of this analysis is subsequently used to structure analysis work, checks and dialog with stakeholders. See Figure 2.

- d. **Context Analysis.** This analysis identifies/validates mainly external interface requirements. The analysis also contributes to environmental requirements. Context analysis helps identify additional stakeholders in the system: owners of interoperating systems; individuals who will interact with the system; and organizational entities with which the system will interface. Context analysis sets the foundation for subsequent capture and validation of required functionality. See Figure 3.

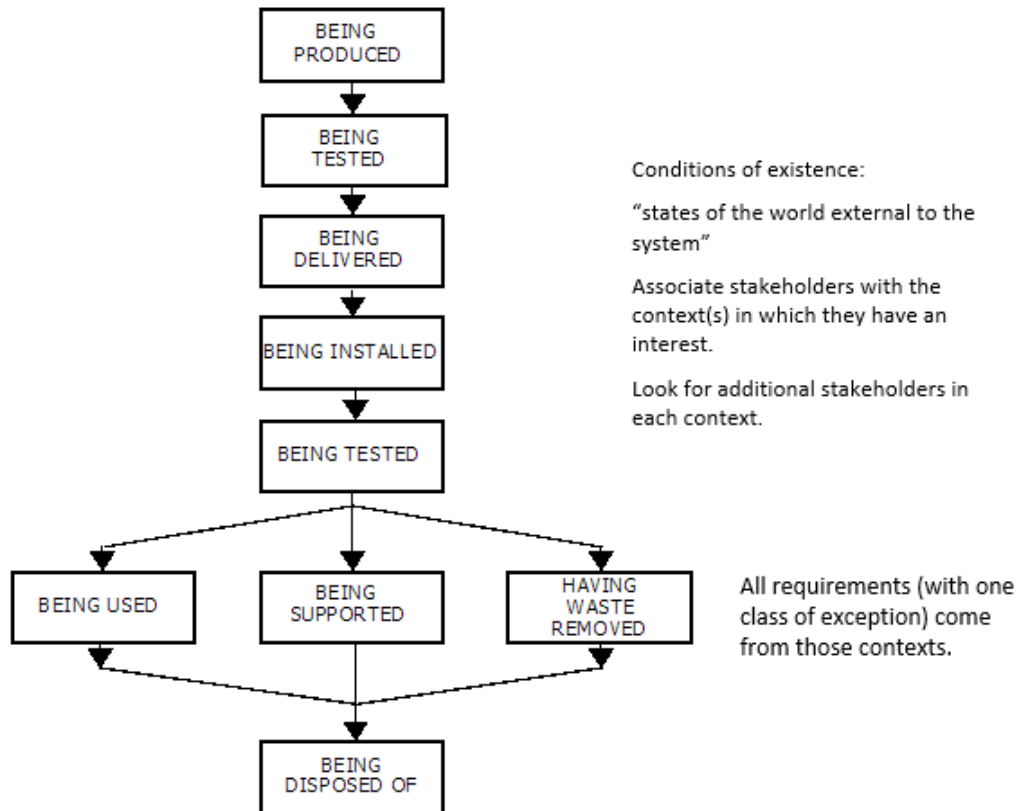

Figure 2: Context Flow Diagram

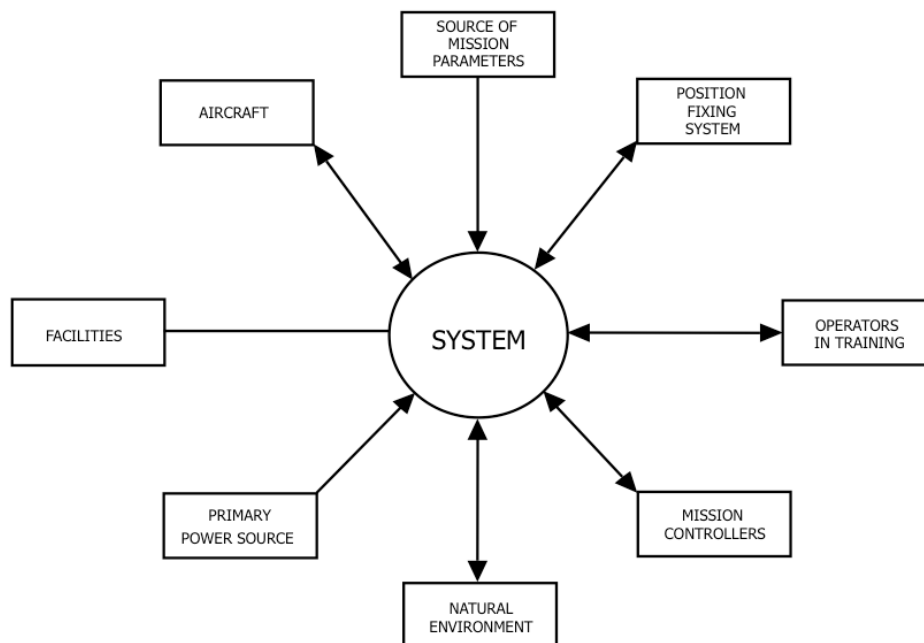

Figure 3: Context Diagram

- e. **States and Modes Analysis.** This is a high ROI analysis, which establishes the big-picture dynamics required of the system, expressed in terms of states & modes. States and modes analysis often identifies major requirements issues. The analysis also establishes preconditions for subsequent precise and concise specification of the requirements captured in other analyses. See Figure 4.

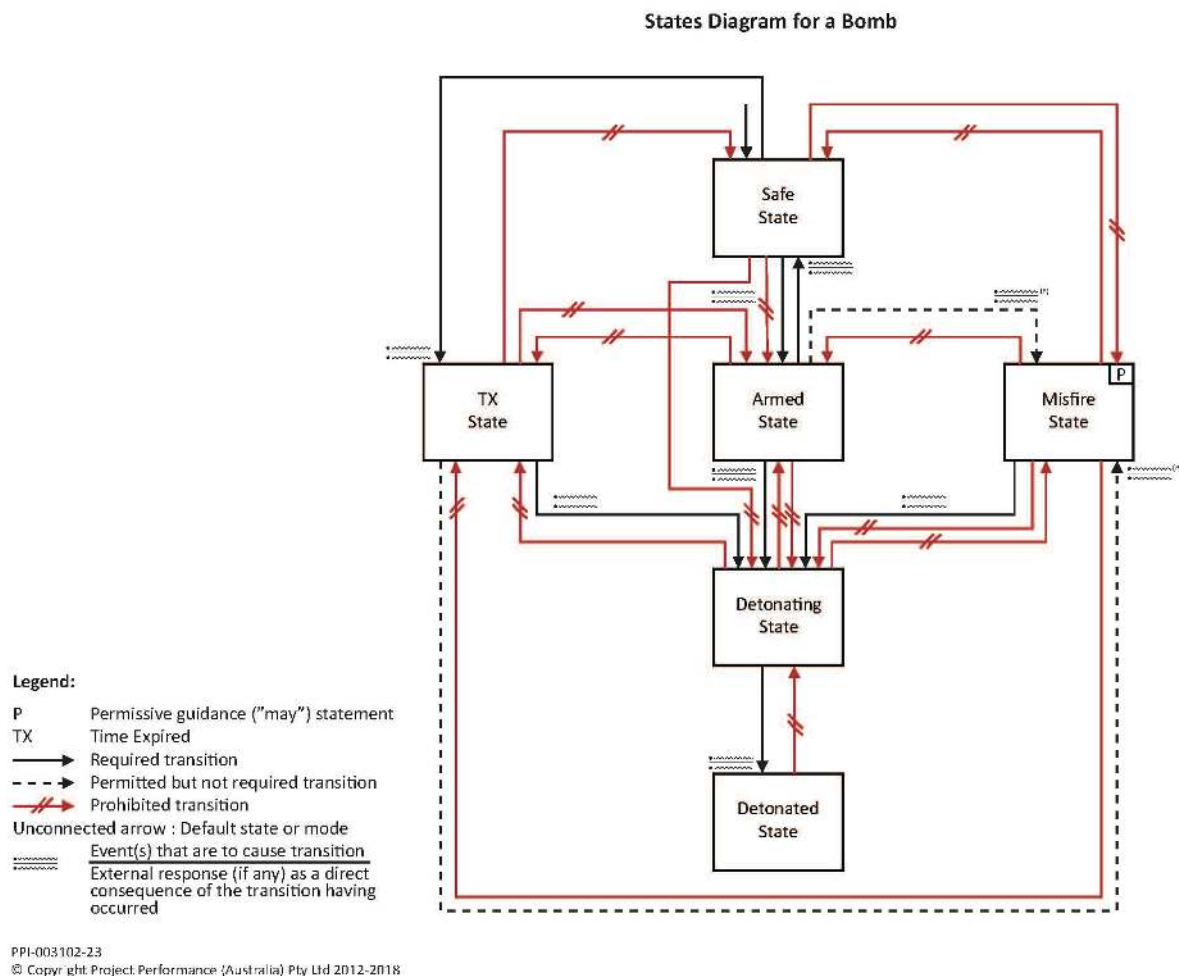
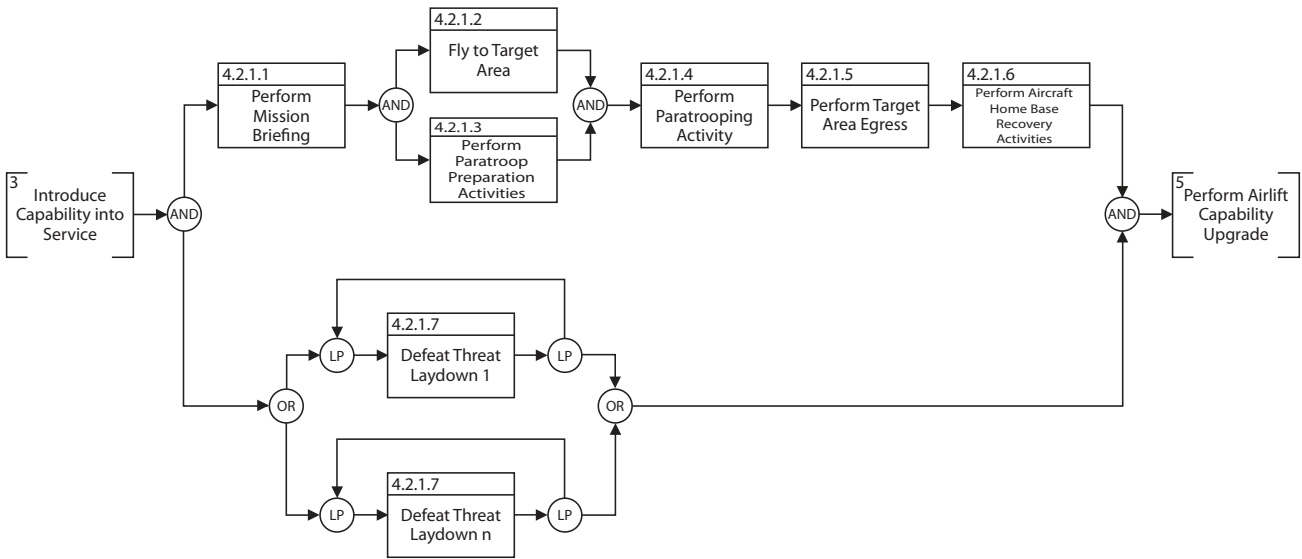

Figure 4: States Transition Diagram

- f. **Functional Analysis.** This analysis is conducted within a modeling boundary which encapsulates enough of the problem, including functional aspects of operational scenarios, to capture and validate the required system functional and performance requirements. The result is a set of functional and performance requirements which is sufficiently complete and is at precisely the correct level of abstraction, neither too broad nor at a level of abstraction which directs the implementation of the system, as opposed to capturing the need. Use cases are a basic form of functional analysis; more robust functional modeling techniques can be used for more demanding applications.



PPI-005642-2

Figure 5: Functional Flow Block Diagram

- g. **Rest of Scenario Analysis.** This analysis, conducted iteratively with functional analysis, identifies/validates environmental requirements, physical requirements, resource requirements and contributes additional content to external interface requirements.
- h. **Entity Relationship Attribute Analysis.** ERA analysis provides input to capture/validation of additional information content of external interface requirements, and some aspects of functional requirements. The analysis is most relevant to data-oriented systems.

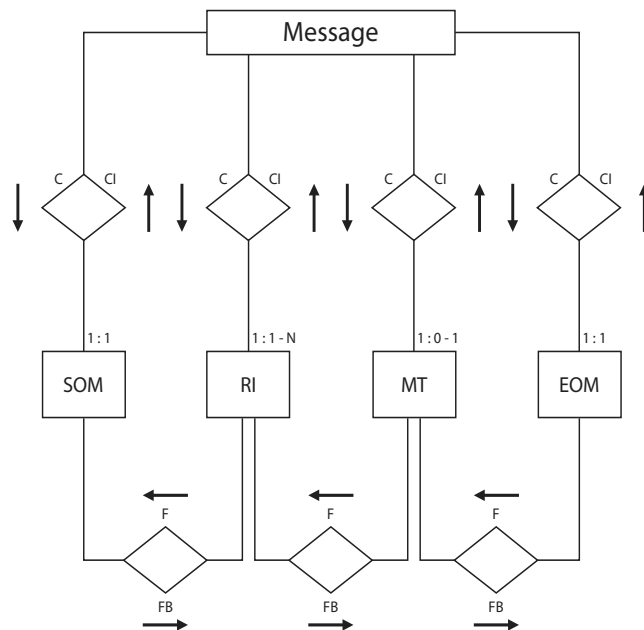

Figure 6: Entity Relationship Attribute Diagram

- i. **Parsing Analysis.** Parsing analysis is a text analysis technique for identification of errors, incompleteness, inconsistency, lack of clarity, ambiguity, lack of verifiability, and infeasibility, in textually stated requirements. The basis of the technique is illustrated in Figure 7:

Actor:	The system,
Condition:	upon receipt of a message,
Action:	shall switch
Object of Action:	that message
Constraints of Action:	within 10 milliseconds of receipt,
Refinement of Object:	for messages in ACP128 format having a valid routing indicator,
Source of Object	from the message input port,
Destination of Action:	to a message output port,
(Further) Refinement of Action:	corresponding to the routing indicator in the message.

PPI-006785-1

Figure 7: Parsing Template

The parsing template also provides an excellent aid to writing good requirements the first time, and for rewriting defective requirements.

- j. **Out-of-Range analysis.** This analysis captures and validates any requirements that relate to defective inputs or outputs or abnormal conditions of use/support/disposal. The requirements from this analysis can make the difference between a system that will be effective in the real world, and a system that could be effective only in the ideal world.
- k. **Other Constraints Search.** This activity looks for requirements which are ordained from on high (such as from statute law, applicable regulations, policy, governing standards, directives).
- l. **Clean-Up.** This activity verifies the refined requirements set, looking for residual defects in the work products of the analysis. Keyword searching is used in combination with specific verification criteria.

**Conclusion:**

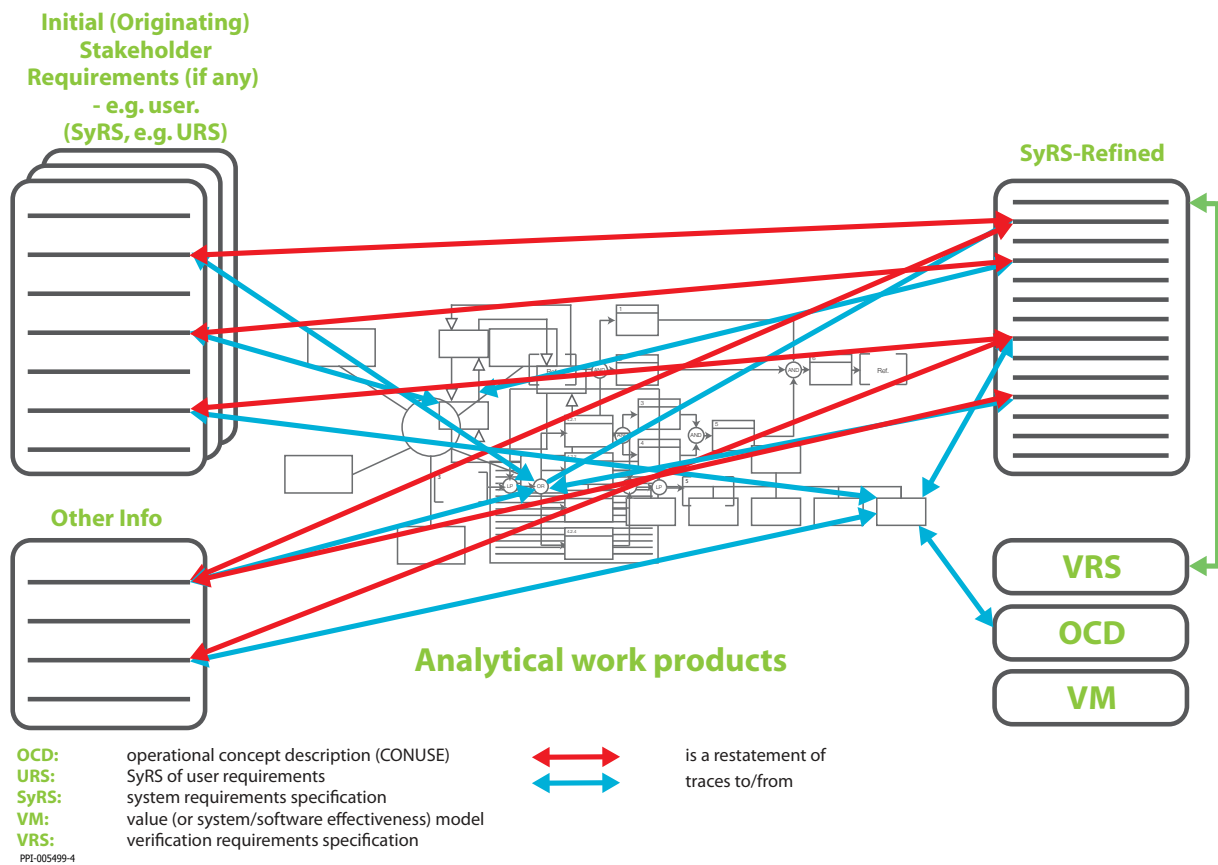

Figure 8: Approach to Requirements Analysis

Methods exist to perform requirements capture and validation both efficiently and very effectively. The methods rely, not on requirements elicitation per se (which is neither efficient nor effective), but on elicitation of responses from stakeholders to specific requirements issues identified mainly through effective analysis of the problem domain.

---

## ARTICLE

---

### 3.2 Integrating Program Management and Systems Engineering

Feb 2019 Update on the INCOSE – PMI Alliance

by

Randall Iliff

Principal Consultant & Course Presenter

Project Performance International (PPI)

Email: [rilliff@ppi-int.com](mailto:rilliff@ppi-int.com)

Hi,

Each year INCOSE members gather for the International Workshop, known simply as "IW". If you've never had the opportunity to attend I think you'll find the experience both enriching and exhausting. The enrichment comes from the exposure to so many ideas in one place, together with the joy of renewing old friendships and adding new ones. The exhaustion is a by-product of honoring the IW objective to get as much work done as possible in a very short period of time.

### **PM-SE Integration Activity at this Year's INCOSE IW**

There were two scheduled meetings related to this topic, one a closed session in which the updated MOU between INCOSE and PMI was reviewed by representatives from both organizations, and a second open meeting in which plans were shared with the community at large. The nature of IW generates a number of valuable hallway and event interactions, I'll mention a few of those as well!

The proposed PMI-INCOSE MOU was reviewed and, following a few minor changes and clarifications, the updated document was deemed ready to submit for PMI detailed review.

The MOU now reflects three "layers" of joint activities. These were shared openly with the PM-SE Integration Working Group:

1. Concentrate on reaching key influencers - those who can actually drive change in the way PM and SE effort is integrated within their organizations or throughout their sphere of influence.
2. Establish the means by which the two organizations will reach this intended audience, defining required actions / events / responsibilities.
3. Leverage the INCOSE PM-SE Integration Working Group to identify projects of mutual interest, as well as identify and connect like-minded parties within the PMI community.

Let's take a few moments and look at each of these individually.

#### **1. Identify the influencers**

We clearly have a powerful message, but our small pool of resources has only limited capacity to broadcast that message to those who need it. We must, therefore, enlist the assistance of others on our behalf. In this case, it means bringing the message of PM-SE Integration to those individuals in a position to spread the message more broadly.

The people we seek are leaders who are either already convinced, or are convincible, and thus free to focus on action instead of argument. We seek managers who are willing to take the risk that an unfamiliar idea may turn out to be the next great business enabler. We seek teachers who understand that PM and SE are infinitely more valuable as integrated concepts than when presented alone. We seek communicators, people who have a platform and enjoy bringing fascinating ideas to new audiences.

Fortunately for our purposes, both PMI and INCOSE have strong industry relationships. The PMI Global Executive Council, along with the INCOSE Corporate Advisory Board, offer an excellent starting point for our search.

## **2. Establish the means**

We live in a world filled with distractions and messages competing for our time. All of that noise competes with us as well, since we are in effect trying to "market" our story along with everyone else. The audience expects to be entertained as well as informed, for complex ideas to be broken down into friendly little parts, and for it all to be over in less than 90 seconds.

"What?" you say, "How can anything as magnificent as the grand potential of PM and SE working in harmony be shared that quickly?"

The answer of course is that it cannot, but that isn't the point of first contact anyway. Our goal is simply to open a channel of communication so that interested parties can draw more and more content on a "pull" basis rather than having stuff "pushed" at them.

Our "means of communication" is therefore not likely to be a single event or product, but rather a layered family of communication resources. The critical change is to focus on the first-contact layer rather than creating additional deep content such as the 2017 book.

## **3. Leverage resources**

As with most goals, the key challenge will be finding sufficient resources to overcome standing inertia and begin forward motion. The INCOSE PM-SE Working Group has roughly 100 members at this time and has a lot of energy and talent to draw upon.

Still, 100 members works out to about one half of one percent of all INCOSE. Given that nearly the entire membership of INCOSE interacts with PM in some way, surely there are more people willing to step up and make a difference.

Resources are an interesting challenge on the PMI side as well, since there isn't a direct equivalent of the INCOSE Working Group structure. At the moment, the PM dimension is reflected in discussion mostly thanks to dual membership of PMI / INCOSE members who are part of the PM-SE Working Group.

Encouraging local chapter connections between INCOSE and PMI activity is thus an appealing option to pursue, bringing with it the potential for not only additional resources but also a scalable model for establishing joint interaction. We also align with the idea of a "pull" model when local groups reach out for suggestions on how to make a difference.

I also promised to mention insights gained during hallway and event interaction, but I'll keep it simple and just focus on one: People tend to keep score in terms of big newsworthy steps, but no one ever climbs six flights of stairs in a single leap. We see six flights and do nothing, when in reality the steps that would take us there are easy to climb one or two at a time.

Anything you do, whether a conversation in an elevator, online post, a guest lecture for a class, or pitching a new approach at work, can all help move the community of PM and SE closer together. I look forward to hearing your thoughts and suggestions, and to sharing progress with you throughout the year.

All the best,

Randall Iliff



---

## 4. SYSTEMS ENGINEERING NEWS

---

### 4.1 INCOSE International Workshop 2019 Working Group Results

The INCOSE Working Groups have established a Working Group Information Sheet (WIS) to help INCOSE Members learn more about the Working Groups and decide where to get involved. The WIS contains some basic information about the Working Group as well as their results from IW2019 which took place in Torrance, California in January 2019. The WISs displayed at the Market Place which took place at the end of IW2019 may be accessed [here](#).

---

### 4.2 INCOSE is Forming a Telecommunications Working Group

The Systems Engineering Society of Australia has had a Telecommunications Working Group since 2017. The Working Group is looking to extend to a formal INCOSE Working Group, opening up to the international systems engineering community. To this end, two sessions were held at INCOSE's International Workshop in Torrance, CA in January: review of work done to date, plus a workshop on "Guide to the Application of Systems Engineering to Large Communications Network Systems"; and, working sessions on a Working Group Charter and future planning. For more information, contact Working Group Deputy Chair, Dan Spencer, at [dan@spencertech.com.au](mailto:dan@spencertech.com.au).

---

### 4.3 Upcoming INCOSE Paper Certification Exam in Orlando, Florida

April 8 - IEEE SysCon (Orlando, FL)

**Not yet certified?** The next paper exam will take place at the 13<sup>th</sup> annual IEEE Systems Conference on 8 April in Orlando, Florida. If you are looking for a list of paper examination locations and dates, visit the INCOSE site at: <https://www.incose.org/systems-engineering-certification/certification-exams>

**Already certified?** You may be eligible to become a Certification Application Reviewer (CAR). All ESEPs are eligible, and CSEPs with at least twenty years of experience may qualify. Email [certification@incose.org](mailto:certification@incose.org) if you'd like to become a CAR. There is mandatory in-person training, which will be offered at both the IW and IS, as well as at some regional conferences.

The next paper exam is scheduled to take place on 19 April in Toulouse, France.

---

### 4.4 INCOSE Webinar: Machine Assisted Requirements Inspection and Evaluation (M.A.R.I.N.E)

#### Abstract

Many systems today are software-intensive. A software-intensive system is, by definition, any system where software influences to a large extent the design, construction, deployment, and evolution of the system as a whole. This includes computer-based systems ranging from individual software applications, information systems, embedded systems, software product lines and product families and systems-of-systems (ISO/IEC/IEEE 42010). Measuring software size is an important tool for setting budgets, bidding

on work, and initiating project control. Function Point (FP) software sizing is a process that quantifies functionality delivered to the user based on the logical design. FPs provide a technology-independent measurement and are an ISO-standardized process. FPs are typically used to measure software for the purposes of quality/productivity analysis, benchmarking, and cost/resource estimation. However, accurate software size estimation can be a challenge for most organizations due to the scarcity of trained personnel and the very time-consuming nature of the process. One answer to this problem is to automate the software sizing process as well as provide users with real-time guidance and assistance as they conduct their size estimates. Machine Assisted Requirements Inspection and Evaluation (MARINE) automates functional software size estimation and requirements analysis by applying Artificial Intelligence and Natural Language Processing (NLP) techniques to review the quality of software requirements and then applying the FP counting process to them. MARINE is developed in Python, and it is a desktop application that interfaces with Office software. MARINE benefits include but are not limited to: providing immediate feedback on the clarity of requirement statements, identifying and removing duplicate requirements, displaying entity and object relationships, calculating FP counts on a given set of requirements, and providing ROM effort and schedule estimates.

## Biography

Amar Zabarah has more than 9 years of Systems Engineering, Research and Development (R&D), and Operations Research (OR) experience in gathering, defining, and structuring requirements of systems for clients' needs; identifying and designing processes; developing program estimates; building project schedules, budgets, forecasts, and plans; conducting detailed system analyses; and providing acquisition recommendations. Mr. Zabarah is widely respected by Logapps clients for his superior systems approach to tackling difficult IT problems and identifying optimal strategic decisions. Mr. Zabarah has worked in commercial and federal settings, including the National Oceanic and Atmospheric Administration (NOAA), US Army, US Navy, US Air Force, Administrative Office of the US Courts (AOUSC), Internal Revenue Services (IRS) and the Office of the Under Secretary of Defense (OUSD). He is a certified Associate Systems Engineering Professional (ASEP) by the International Council on Systems Engineering (INCOSE) and is pursuing the Certified Systems Engineering Professional (CSEP) designation. Mr. Zabarah is also the MARINE Project Manager. Mr. Zabarah holds a BS in Systems Engineering and MS in Operations Research from George Mason University.

The webinar took place on 16th January 2019 but is available for viewing by INCOSE members through the INCOSE Connect portal at this address:

<https://connect.incose.org/Library/Webinars/Pages/INCOSE-Webinars.aspx>

---

## 4.5 INCOSE Webinar: Encouraging Broader Engagement and Collaboration across the Enterprise using MBSE Tools

### Abstract

As model-based methodologies and the tools to support the systems engineering function are becoming mandatory in engineering projects, team managers are challenged with encouraging all stakeholders to share information and decisions from their own activities through the systems model as the "single source of truth". Traditionally, this would be achieved by either forcing all stakeholders to learn to use the same tools as the systems engineers, or transfer the information through documents, spreadsheets,

emails, and frequent design review meetings. Either approach introduces significant risk and can lead to missing or erroneous data, causing problems later in the process that can be extremely costly and disruptive to the project.

In this webinar, attendees will hear from NASA's Jet Propulsion Laboratory (JPL) about a recent pilot project that introduced ways to broaden engagement with their SE practices using MapleMBSE, a tool that uses Excel as the user interface. MapleMBSE provides a technology that generates task-specific views into the system model, serving up the relevant information in tabular or matrix forms that can be directly edited, all with a live connection to the systems model. This allows stakeholders, from all disciplines and functions throughout the enterprise, to collaborate via the model and engage more effectively with Systems Engineering process.

Attendees can expect to learn more about the various ways that JPL was able to broaden engagement and collaboration and see how these techniques might apply to their own organizations.

### **Biography**

Eric W Brower is a Software Systems Engineer at Jet Propulsion Laboratory (JPL) working primarily in Computer Aided Engineering (CAE). In the Engineering Tools and Data Management group, he provides support of the CAE Systems Environment for engineers at JPL. He is embedded on the Europa Lander Flight System Engineering Team. In this embedded role, he adapts the standard CAE Systems Environment to the specific needs of the project.

Paul Goossens is the Vice President of MBSE Solutions at Maplesoft. A mechanical engineering with over 20 years of experience in both engineering and software business management, his previous roles include senior management positions for companies in the fields of system-level modeling and simulation. He oversees the Systems Engineering Solutions Business Unit that provides tools and services to support customers' Model-Based Systems Engineering (MBSE) processes for product design and operation. At the core of his activities is Maplesoft's latest product, MapleMBSE, an Excel-based tool to help democratize the SE process and broaden SE engagement across the enterprise.

This webinar will take place on Wednesday March 13th 2019 from 11am to 12pm EDT (4pm – 5pm UTC)

To register for the webinar, follow [this](#) link.

---

## **4.6 Space and Naval Warfare Systems Command Updates Dictionary for Interoperability**

*Story by*

Elisha Gamboa

(Public Affairs Specialist)

To continue to foster interoperability of engineering systems, Space and Naval Warfare Systems Command (SPAWAR) (USA) has updated its dictionary of common lexicon for use in all engineering efforts throughout the command and with fleet customers.

Version 2.2 of the SPAWAR Enterprise Architecture Integrated Dictionary provides key updates in an ongoing effort to standardize engineering language across SPAWAR projects.

A common challenge facing today's Navy is that engineers use different terms to describe the same thing when developing systems, meaning systems are not able to communicate, thus causing a disconnect between Navy systems once delivered to a ship.

SPAWAR's dictionary is the first step in ensuring the interoperability of SPAWAR-developed Navy systems prior to installation. It provides engineers with a list of standardized terms to use when developing a system or building a model. Standardized vocabulary allows systems to communicate clearly, to speak the same language and to successfully work together.

"The integrated dictionary is a valuable engineering resource, providing engineers with authoritative, validated, pedigreed terms and definitions," said Michele Cott, SPAWAR's enterprise architect and lead developer for the dictionary.

The first version of the SPAWAR Enterprise Architecture Integrated Dictionary was launched in June 2017. It is updated quarterly, with the most recent version (2.2) containing significant updates.

Not only has the dictionary been successful at SPAWAR, it is also being used by other Department of the Navy (DoN) systems commands (SYSCOMs) in support of cross-SYSCOM projects.

"The integrated dictionary has been implemented within our modeling repository allowing us to consistently communicate and reuse definitions and terms as they relate to our integrated systems development efforts," said Matt Ralston, SPAWAR Systems Center Atlantic, Military Sealift Command shipboard management information system project lead.

By providing standardized, authoritative terms, SPAWAR's dictionary reduces the time, energy and cost of new and revised engineering efforts, eliminating redundancy and improving data integrity.

"The integrated dictionary is so valuable, and so necessary," said Sam Rix, SPAWAR system of systems engineering analyst. "It provides accurate and reusable architectures, allowing any engineer to use one architecture and plug it into another."

The SPAWAR Enterprise Architecture Integrated Dictionary is a living document. Terms included in the dictionary are sourced from experienced engineers, authoritative Navy doctrine, and DoD regulations. As authoritative sources are revised, the dictionary is also revised. Similarly, as SPAWAR develops new architectures, the team will identify new terminology and make the necessary updates.

"Frequent updates ensure accuracy and save engineers time gathering and validating the information, in turn, enhancing speed to delivery," said Cott. "Ultimately it enables smarter engineering across the Navy and Department of Defense."

Any Naval Systems Engineering Resource Center (NSERC) registered common access card (CAC) user can access the enterprise architecture integrated dictionary.

The dictionary is available for use upon request for all government personnel. For more information on the SPAWAR Enterprise Architecture Integrated Dictionary contact lead developer Michele Cott at [michele.cott@navy.mil](mailto:michele.cott@navy.mil).

SPAWAR identifies, develops, delivers and sustains information warfighting capabilities supporting naval, joint, coalition and other national missions. SPAWAR consists of more than 10,000 active duty military and civil service professionals located around the world and close to the fleet to keep SPAWAR at the forefront of research, engineering and acquisition to provide and sustain information warfare capabilities to the fleet.

---

## 4.7 International Institute of Business Analysis (IIBA) Introduces New Agile Extension to BABOK Guide

The International Institute of Business Analysis has introduced an Agile Extension Version 2 to the Business Analysis Body of Knowledge. The Agile Extension to the BABOK® Guide describes both the mindset and practices to help users use continuous feedback and quick learning to prioritize delivery, minimize waste, create better business outcomes and increase value delivered.

Based on experiential learning, the Agile Extension introduces a rolling planning model with three planning horizons – strategy, initiative and delivery – to help users adapt quickly to changing customer needs and ensure value is always added.

Version 2 incorporates the Business Analysis Core Concept Model™ and new and updated techniques, including Feature Driven Development, Impact Mapping, Value Modelling and Visioning.

Developed in collaboration with the Agile Alliance, the Agile Extension to the BABOK® Guide provides guidance for agile practitioners, or anyone interested in leveraging effective agile business analysis to create better business outcomes that add real business and customer value.

[More Information](#)

---

## 4.8 Zuken Solutions to Acquire Vitech

29 January 2019 – Westford, MA, USA – Zuken Inc (6947:TYO) announced an agreement to purchase Vitech Corporation for an undisclosed amount. Vitech is a global solutions company based in Blacksburg, VA, United States, specializing in systems engineering, with products and services directed at the Model-Based Systems Engineering (MBSE) market.

As product complexity continues to increase, companies are adopting MBSE tools and processes to better define product requirements, structure and behavior. Vitech Corporation's GENESYS product is a MBSE software tool that incorporates the key components of building a complex system involving people, processes, data, and documentation. Companies in the aerospace, transportation and military segments rely on Vitech to enhance their system engineering processes and outcomes.

Zuken is a global provider of electrical and electronic design, and data management solutions to a range of industries that includes automotive, transportation, aerospace, and consumer electronics. Zuken's global brands include CR-8000, a native 3D multi-board / IC packaging design platform; and E3.series, an industry-leading wire harness design solution. Vitech will complement and expand Zuken's advanced design technologies portfolio with a systems engineering solutions offering. Vitech will

remain as a separate operating unit and continue to lead in providing advance systems engineering in the greater digital engineering context.

For more information see [www.zuken.com](http://www.zuken.com) and [www.vitechcorp.com](http://www.vitechcorp.com)

---

## 4.9 INCOSE is Looking for New Members to Join TechOps

At the INCOSE International Workshop (IW) in Torrance, California (January 2019), newly appointed Technical Operations Director David Endler announced that INCOSE is looking to appoint new persons into the following positions:

- Deputy Assistant Director Technical Events (immediately)
- Deputy Assistant Director Technical Review (immediately)
- Assistant Director Analytic Enablers (July 2019)
- Assistant Director Application Domains (July 2019)
- Assistant Director Internal Operations (July 2019)
- Assistant Director Process Enablers (July 2019)

If you are interested in fulfilling any of the above roles, please contact [technical-director@incose.org](mailto:technical-director@incose.org).

---

## 4.10 INCOSE Announces Systems Engineering Mentors/Mentees Program

At the INCOSE International Workshop (IW) that took place in Torrance, California in January 2019, INCOSE announced their new mentor/mentee program dedicated to connecting mentors and mentees for the proliferation of SE knowledge and wisdom from more experienced to less experienced engineers. The Engineering Women as Leaders in Systems Engineering (EWLSE) is sponsoring the INCOSE Mentor/Mentee 'Matching' Program for all INCOSE members and is actively seeking participants for this exciting program.

All levels of experience are welcomed. If you have an interested in partaking in this initiative, send any questions or expressions of interest through to [incose-mentor@incose.org](mailto:incose-mentor@incose.org).

---

## 4.11 Annual GfSE Workshop

07 – 08 March 2019 (Hannover, Germany)

Gesellschaft für Systems Engineering e. V (the German Chapter of INCOSE) is hosting its annual workshop in March to bring together interested persons who are dedicated to research in the overall context of Systems Engineering. The GfSE workshop is open to members and non-members and provides the opportunity for participants to develop new knowledge and skills related to SE.

The workshop is targeted at issues that are encountered in everyday life with a goal of producing tangible products that can offer benefit to the public.

The following projects are available:

- GfSE Systems Engineering Manual
- MBSE collaboration and SysML model exchange
- System Architecture Framework (SAF) - Development of concept and profile model
- Systems engineering of safety critical systems
- Systems Engineering Quick Check

Details information about the projects for the GfSE Workshop 2019 are accessible [here](#).

You can register for the workshop using the following link: <https://www.workshop.gfse-shop.de>

[More Information](#)

---

## 4.12 Presentation: V-Model Approach to K-12 Learning

### Synopsis

Engineering has been relatively absent from the K-12 classroom for years, but the Next Generation Science Standards has challenged this absence. Forty states in the USA have shown interest and nineteen states, including all states along the west coast, have adopted the Next Generation Science Standards (NGSS). These standards incorporate science and engineering practices into every grade level.

The V-Model for systems engineering was adapted for the K-12 classroom. This approach allows for students to think strategically while performing systems analysis, systems validation, verification of requirements, project planning, and decision management. This presentation will look at how this Vee-Model systems engineering approach has been integrated into the classroom to engage young minds in innovation through collaboration, problem solving, negotiating requirements and critical thinking.

**Presenter:** Becky McKinney, Escondido Union High School District

Becky McKinney is a secondary science educator and teacher on special assignment (TOSA) in the Escondido Union High School District. She leverages her prior experiences as a forensic scientist, neuroscientist and college educator in order to bring a passionate and nontraditional approach to STEM learning. Through her work with engineers, she has developed a method to bring systems engineering into any classroom utilizing the V-model. She is a member of the California Science Teacher's Association and National Science Teacher's Association and has received numerous awards for her dedication to student learning.

### Presentation details

**Date:** Wednesday, February 27th, 2019, from 5:30-7pm

**Location:** Filippi's Restaurant in Kearny Mesa, 5353 Kearny Villa Rd, San Diego, CA 92123

**Cost:** Free

**Presentation and Dinner:** The first 1/2 hour is for dinner and networking. The optional buffet dinner starts at 5:30 and the presentation begins at approximately 6 pm. The cost of the buffet is \$10 for

members, \$15 for non-members, and includes pizza, salad, pasta, and soft drinks.

**Webcasting:** This presentation will be webcast starting at approximately 5:50 pm. You will be able to view the presentation slide show and hear audio from the speaker. Please note that during the phase-in period, the hosts will not take questions from the webcast audience. Please note that the webcast quality depends on our venue's Internet connection (it has been mostly dependable in the past).

RSVP to the presentation [here](#).

---

## 5. FEATURED ORGANIZATIONS

---

### 5.1 Systems Society of India

Systems Society of India (SSI) is a professional body of distinguished engineers and scientists from engineering, science, social studies and the arts disciplines. It promotes advancement of theory, research, application and practice keeping in view the holistic systems approach for the advancement of humankind. SSI sponsors an annual event, the National Systems Conference (NSC) that is devoted to strengthening the systems movement and its applications. It provides a forum for sharing knowledge and disseminating research findings. "With the increasing prevalence of complex systems in modern society, and the essential role of systems engineering in the development of systems, it is extremely important to develop synergy among system engineers in the country and to provide a platform for exchanging ideas in the latest trends/approaches in system engineering approach," the organizers said.

[More Information](#)

---

### 5.2 Waters Foundation for Systems Thinking

The Waters Foundation helps create positive change and improved performance through the habits and tools of systems thinking. The Waters Foundation is dedicated to delivering benefits and working with others to help them do the same — whether it's in a classroom, school, district, business or community. Systems thinking helps people of all ages and walks of life see beyond the heart of a problem to find equitable and essential solutions.

The Foundation's work is recognized worldwide for making systems thinking accessible and practical, both for children in classrooms as well as executives in boardrooms. The people at Waters Foundation have worked across the U.S. and around the globe to develop systems thinkers who will shape the current and future world by understanding the complexities of the systems we live and work in, and identifying leverage actions to achieve desired results.

[More Information](#)

---

## 6. NEWS ON SOFTWARE TOOLS SUPPORTING SYSTEMS ENGINEERING

---



## 6.1 Phoenix Integration and PTC Introduce ModelCenter MBSE for PTC Integrity Modeler

ModelCenter MBSE 1.0.1 for PTC Integrity Modeler is the first product to utilize Phoenix Integration's next generation MBSE integration platform – ModelCenter MBSE.

ModelCenter MBSE 1.0.1 for PTC Integrity Modeler allows engineers to validate system behavior and performance using any software application:

- Connect any software application to PTC Integrity Modeler's system models:
  - i. COTS tools such as Excel®, MATLAB®, and Simulink®
  - ii. CAE Tools such as HyperWorks®, NASTRAN®, ABAQUS®, and ANSYS®
  - iii. CAD Tools such as Creo®, NX®, CATIA v5®, and SolidWorks®
  - iv. Legacy FORTRAN or C++ applications
  - v. Python, Java, and VB scripts
  - vi. Databases and PDM/PLM solutions
  - vii. Almost anything else
- Run the connected simulation directly from PTC Integrity Modeler's unique SySim:
  - i. Graphical functional co-simulation
  - ii. Direct interaction with simulation parameters
  - iii. Record simulation results with optional model import
- Validate system behavior and performance early in the lifecycle
- Close the simulation loop, comparing models with the real world

A webinar demonstrating the upcoming release was held on the 24<sup>th</sup> January 2019 and is accessible [here](#).

[More information](#)

---

## 7. SYSTEMS ENGINEERING PUBLICATIONS

---

### 7.1 Feature Engineering Made Easy

*by*

Sinan Ozdemir

*and*

and Divya Susarla



[Image Source](#)

From the Amazon Website:

Feature engineering is the most important step in creating powerful machine learning systems. This book will take you through the entire feature engineering journey to make machine learning much more systematic and effective.

You will start with understanding your data; often the success of your ML models depends on how you leverage different feature types, such as continuous, categorical, and more. You will learn when to include a feature, when to omit it, and why, all by understanding error analysis and the acceptability of your models. You will also learn to convert a problem statement into useful new features. This book will guide you in delivering features driven by business needs as well as mathematical insights, and you'll see how to use machine learning for your data.

By the end of the book, you will have become proficient in feature selection, feature learning, and feature optimization.

### **What you will learn**

- Identify and leverage different feature types
- Clean features in data to improve predictive power
- Understand why and how to perform feature selection and model error analysis
- Leverage domain knowledge to construct new features
- Deliver features based on mathematical insights
- Use machine learning algorithms to construct features

- Master feature engineering and optimization
- Harness feature engineering for real-world applications through a structured case study

### Who This Book Is For

If you are a data science professional or a machine learning engineer looking to strengthen your predictive analytics model, then this book is a perfect guide for you. Some basic understanding of machine learning concepts and Python scripting would be enough to get started with this book.

Format: Paperback, Kindle

Publisher: Packet Publishing - ebooks Account (January 22, 2018)

ISBN-10: 1787287600

ISBN-13: 978-178728760

[More Information](#)

---

## 7.2 INCOSE SoS Primer

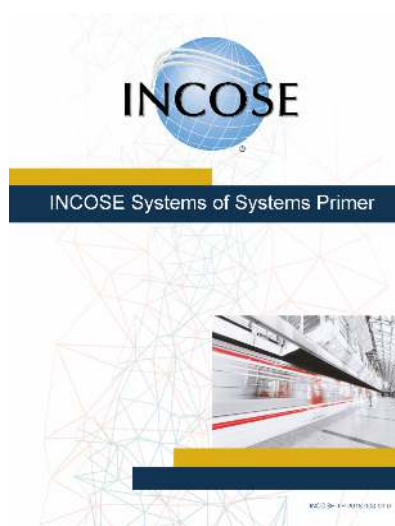

[Image Source](#)

### What is a System of Systems?

A System of Systems (SoS) is a collection of independent systems, integrated into a larger system that delivers unique capabilities. The independent constituent systems collaborate to produce global behavior that they cannot produce alone. Systems of Systems is becoming a topic of increasing interest. The SoS working group has been implementing a set of activities including monthly global webinars and a special issue of INSIGHT, the INCOSE Practitioners' Magazine, focused on SoS to support information exchange on systems engineering for SoS.

### What is the Systems of Systems Primer?

The SoS Primer is intended to reach a broader audience. The primer will serve as an effective introduction to the SoS area, while also providing a roadmap for the reader on where to find additional information.

[More information](#)

---

## 7.3 INCOSE Systems Engineering Competency Framework



[Image Source](#)

The INCOSE Competency Framework provides a set of 36 competencies for Systems Engineering within a tailorable framework that provides guidance for practitioners and stakeholders to identify knowledge, skills, abilities and behaviors crucial to Systems Engineering effectiveness.

The INCOSE Competency Working Group (CWG) produced the framework to improve the practice of Systems Engineering. The framework along with adoption of effective competency management approaches is intended to be used by customer organizations to produce competency models specifically tailored to their unique needs.

This INCOSE Competency Framework is a generic framework. It can be applied in the context of any application, project, organization or enterprise for both individual and/or organizational assessment and/or development. The framework is expected to be tailored to suit the application and domain in which it is applied, combining competencies identified herein with others taken from complimentary frameworks (e.g. Program Management, Human Resources, Aerospace, Medical), or generated organizationally, to define the required knowledge, skills and behaviors appropriate to an area or role.

[More Information](#)

---

## 7.4 Systems Engineering for Projects: Achieving Positive Outcomes in a Complex World (Best Practices in Portfolio, Program, and Project Management)

*by*

Lory Mitchell Wingate

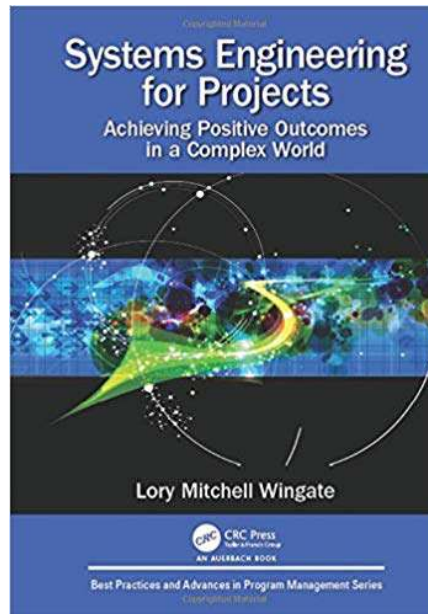

[Image Source](#)

From the Amazon Website:

Systems engineering has been applied to some of the most important projects of our time, including those that have helped humanity explore the world and the universe, expand our technical abilities, and enhance the quality of human life. ***Systems Engineering for Projects: Achieving Positive Outcomes in a Complex World*** provides an approach that utilizes a combination of the most effective processes from both project management and systems engineering disciplines in a simplified and straightforward manner. The processes described in the book are lightweight, flexible, and tailorable. They provide the shortest path to success in projects across the entire project life cycle, from research to operations, and from simple to the most complex. The book also addresses how this methodology can be used in a continually adapting and changing world, as projects span disciplines and become even more interconnected across all areas of human existence. Each chapter includes diagrams, templates, summary lists, a case study, and a thought-provoking question and answer section that assists readers in immediate application of the material to their own projects. The book is a resource for understanding how to directly apply essential processes to projects in a way that increases the probability of achieving success. It is a comprehensive, go-to manual on the application of systems engineering processes to projects of all types and complexity.

Format: Hardcover, Kindle

Publisher: Auerbach Publications; 1 edition (September 14, 2018)

ISBN-10: 9780815362951

ISBN-13: 978-0815362951

[More Information](#)

---

## 7.5 Effective Model-Based Systems Engineering

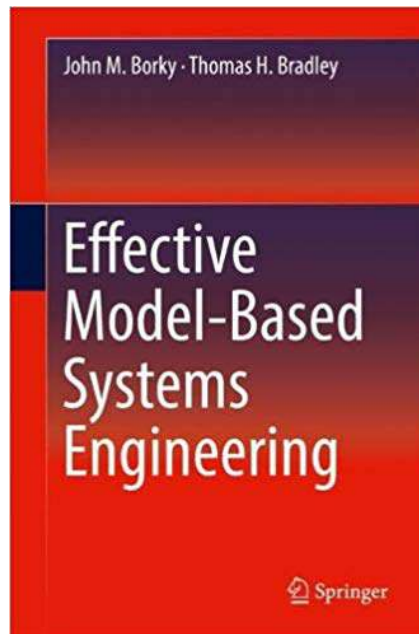

[Image Source](#)

*by*

John M. Borky

and

Thomas H. Bradley

From the Amazon Website:

This textbook presents a proven, mature Model-Based Systems Engineering (MBSE) methodology that has delivered success in a wide range of system and enterprise programs. The authors introduce MBSE as the state of the practice in the vital systems engineering discipline that manages complexity and integrates technologies and design approaches to achieve effective, affordable, and balanced system solutions to the needs of a customer organization and its personnel.

The book begins with a summary of the background and nature of MBSE. It summarizes the theory behind Object-Oriented Design applied to complex system architectures. It then walks through the phases of the MBSE methodology, using system examples to illustrate key points. Subsequent chapters broaden the application of MBSE in Service-Oriented Architectures (SOA), real-time systems, cybersecurity, networked enterprises, system simulations, and prototyping. The vital subject of system and architecture governance completes the discussion. The book features exercises at the end of each chapter intended to help readers/students focus on key points, as well as extensive appendices that furnish additional detail in particular areas. The self-contained text is ideal for students in a range of courses in systems architecture and MBSE as well as for practitioners seeking a highly practical presentation of MBSE principles and techniques.

Format: Hardcover, eTextbook

Publisher: Springer; 1st ed. 2019 edition (September 9, 2018)

ISBN-10: 331995668X

## 8. EDUCATION AND ACADEMIA

---

### 8.1 Portland State University

#### Department of Engineering and Technology Management (ETM)

Portland, Oregon (USA)



[Image Source](#)

The field of Engineering and Technology Management provides the link between engineering, science, and management. It helps companies, research organizations, and governments to plan, develop, and implement technologies. PSU's ETM Department is one of the oldest departments and a recognized world leader in this rapidly growing field. Founded by Dr. Dundar Kocaoglu in 1987 with just 13 part-time Master's students, the department has grown to 250 students in Master's, PhD, and certificate programs. The department has granted over 600 Master's degrees to students from over 40 different countries. It has a very active PhD program and has awarded over 25 doctorates. As a global leader, it has students, alumni, and collaborators around the world.

#### **ETM Education**

ETM offers about 40 graduate courses per year. To serve the needs of working professionals, courses are offered at night, year-round, and at two campuses (PSUs downtown campus and Westside in Hillsboro). Programs offered include:

#### Master of Science in Engineering and Technology Management

1. Graduate Certificates in:
  - Engineering and Technology Management
  - New Product Development

- Technological Entrepreneurship
- Strategic Management of Technology
- Project Management

## 2. Ph.D. in Technology Management

In addition, students regularly combine ETM degrees and courses with graduate study in other departments at PSU. For example, some students obtain a Dual Master's in ETM and another engineering discipline. Others fulfill their minor area requirements in their graduate program by obtaining a Graduate Certificate from ETM.

### **ETM Faculty and Research**

ETM faculty have a strong engineering background and substantial work experience. They work in areas such as decision analysis, benchmarking, innovation, entrepreneurship, new product development, technology road-mapping, knowledge management, technology forecasting, data analytics, and much more. The faculty's research groups can be accessed from the research tab.

### **Research Leadership**

ETM is the home of [PICMET](#) - Portland International Conference for the Management of Engineering and Technology. This conference provides unique opportunities for the ETM community to stay current on research, develop professionally, and to interact with global partners. PICMET started in 1991, when Dr. Kocaoglu held a conference to connect ETM experts across the globe. Initially intended to be a one-time event, PICMET is now held annually. The conference alternates between Portland (typically in odd years) and in international locations, such as Korea, Turkey, and South Africa (in even years). The most recent PICMETs were held in Kanazawa, Japan in August 2014 and in San Jose, California in August 2015. PICMET conferences typically draw about 600 attendees and publish referred and indexed proceedings.

For more information on the ETM Department, email [etminfo@pdx.edu](mailto:etminfo@pdx.edu) or call 503.725.4660.

[Website](#)

---

## **8.2 Electronic Systems Engineering (ESE) at the University of Regina**

**Regina, Saskatchewan Canada**

### **What is Electronic Systems Engineering?**

Electronic Systems Engineering focuses on the integration of electronics, computers, and communication technologies in many different types of systems.



## The Program

The Electronic Systems Engineering (ESE) program at the University of Regina focuses on a core program of analog and digital electronics with specialization streams in: instrumentation and control, telecommunications, micro-electronics, and power and energy.

Software and computer-related courses are part of the electronics core program, allowing students to develop greater facility with both hardware and software.

Graduate with:

- Bachelor of Applied Science (B.A.Sc.) in Electronic Systems Engineering
- Students in Co-operative Education graduate with a B.A.Sc. (Co-op) in Electronic Systems Engineering
- Students in the Internship Program graduate with a B.A.Sc. (Internship) in Electronic Systems Engineering

The ESE program is fully accredited by the Canadian Engineering Accreditation Board.

## ESE Graduate Program

- Master of Engineering (M.Eng.) – project focus or co-op
- Master of Applied Science (M.A.Sc.) – thesis-based
- Doctoral (Ph.D.) program

[More Information](#)

---

## 8.3 Tenure-Track Faculty Positions, Stevens Institute of Technology

The School of Systems and Enterprises (SSE) at Stevens Institute of Technology invites applications for up to five full-time tenure-track faculty positions, starting Fall 2019 or on a mutually agreed upon date. Successful candidates will contribute to a dynamic and growing research and educational program in the areas of smart systems, healthcare systems, cyber physical systems, software engineering, system security, and underlying enabling technologies, such as, machine learning, data engineering, embedded systems, and hardware implementation. Faculty duties include teaching at the undergraduate and graduate levels, advising and mentoring graduate students, conducting externally-funded research, as well as contributing to service to Stevens and to the professional community. Candidates will be expected to become leaders in their field of research, to develop a vibrant externally-funded research program, and to contribute to best-in-class educational programs.

Applicants must possess a doctoral degree in a related engineering or science discipline prior to commencement of employment. To apply, please submit your package as a single PDF file that contains your curriculum vita, research statement, teaching statement, and contact information for 4-5 references

online at Stevens/SSE Career Opportunities, as well as in an email to [sse-search@lists.stevens.edu](mailto:sse-search@lists.stevens.edu). Review of applications commenced on January 2, 2019 and will continue until the position is filled.

Stevens Institute of Technology, The Innovation University®, is a premier, private research university situated in Hoboken, N.J. overlooking the Manhattan skyline.

---

## 9. SOME SYSTEMS ENGINEERING-RELEVANT WEBSITES

---

### **Systems Thinking in Schools, Waters Foundation**

This site contains access to resources, tools and services on offer by the Waters Foundation for the exploration of education, tools and strategies in Systems Thinking to help develop systems thinking habits in children and young adults. There are many valuable resources including a list of online simulators that demonstrate systems thinking concepts visually.

<https://www.watersfoundation.org/>

### **Functional Architecture for Systems Method (FAS)**

Home of the FAS method – a method for the use-case-driven creation of a functional architecture for systems, first published by Jesko G. Lamm and Tim Weilkiens at the TdSE conference in Munich, Germany, in November 2010. The [conference paper](#) is the definition and foundation of the FAS method. The method bridges Systems Analysis and System Architecture, facilitating the work in product realization teams. It is expected to improve re-use in development organizations, based on the notion that functional architecture descriptions are valid across multiple generations of technology.

The sight includes access to training, publications and plugins on the FAS method.

<http://fas-method.org/content/>

### **Project Smart**

Project Smart was launched in 2000 intended to provide easy access to information about project management profession. The website offers free, high quality, ethical content in an accessible from while encouraging open discussion. It provides access to the latest project management thinking from a large group of subject matter experts. This link in particular provides an article titled, 'A Project Manager's Guide to Systems Thinking: Part I'.

<https://www.projectsmart.co.uk/project-managers-guide-to-systems-thinking-part-1.php>

---

## 10. STANDARDS AND GUIDES

---

### **10.1 ISO/PAS 19450:2015 Object-Process Methodology (OPM)**

ISO/PAS 19450:2015 specifies Object-Process Methodology (OPM) with detail sufficient for enabling practitioners to utilize the concepts, semantics, and syntax of Object-Process Methodology as a modeling paradigm and language for producing conceptual models at various extents of detail, and for enabling tool vendors to provide application modeling products to aid those practitioners.

## 10.2 Technology Management Training Manual

### The International Centre for Science and High Technology

The importance of technological activity and innovation for competitiveness is widely accepted in the context of developed industrial countries. It is less well understood that intentional technological efforts are equally important for developing countries, despite their being essentially importers of technologies rather than innovators. Much of the efforts of developing countries are directed towards the acquisition of technological capabilities which can be defined as the skills – technical, managerial, and organizational – required by enterprises to set up and efficiently operate, improve and expand plants over time, and develop new products and processes. Technological capabilities comprise a broad range of functions, from routines needed for factory shop floor operations, to sophisticated jobs involving advanced research. However, technological capabilities are not sufficient on their own to assure competitive advantage; it is also necessary to have the ability to exploit them within a strategic framework. Technology Management (TM), the subject of this manual, refers to all those activities involved in developing and exploiting technological capabilities for sustainable competitive advantage. TM is a necessary and integral part of the efficient industrial development process, and many of the factors that affect the latter determine the former.

This manual on TM is an educational tool. It is meant to guide local educators in TM in developing countries. Because of the significant variations in the level of development and therefore, the managerial skills required to master the technologies, it is recommended that the educator should extrapolate and possibly adapt those topics in this manual to suit the local environment.

Download the manual [here](#).

---

## 11. SOME DEFINITIONS TO CLOSE ON

---

### 11.1 Framework

1. (noun) A basic conceptual structure (as of ideas).
2. (noun) A skeletal, openwork, or structural frame.

*Source: Merriam Webster Dictionary*

### 11.2 Complex

1. (noun) A whole made up of complicated or interrelated parts.
2. (adj) Composed of two or more parts.

*Source: Merriam Webster Dictionary*

### 11.3 Risk

1. (noun) Possibility of loss or injury.

2. (verb) To expose to hazard or danger.

Source: Merriam Webster Dictionary

---

## 12. CONFERENCES AND MEETINGS

---

For more information on systems engineering related conferences and meetings, please go to [our website](#).

The featured event for this edition is:

### SERC Capstone Marketplace Summit

**28 February 2019, Washington D.C.**

The Systems Engineering Research Center (SERC) is a USA Department of Defense (DoD) University Affiliated Research Center (UARC) at Stevens Institute of Technology; the Office of the Deputy Assistant Secretary of Defense for System Engineering (ODASD/SE) sponsors SERC's activities. SERC is chartered to strengthen academic research in systems engineering, addressing problems of interest to DOD. A component of SERC's effort is the "Capstone Marketplace", which connects DOD and other government organizations with undergraduate academic teams, to work on senior year, "capstone" design projects. The Capstone Marketplace is a resource which provides student design teams research topics, contact with government Subject Matter Experts, and research funding for projects. University capstone teams are expected to operate like small industry teams, performing research and development for government "SME" "customers". SERC staff will provide technical, business, and other management references and resources as needed.

SERC's Capstone Marketplace has a list of "[2018-2019 Research Topics](#)". Technical problems, capability gaps, and research interests have been collected from DOD military operators and government research organizations. Government funds are available for student teams willing to tackle these research topics as capstone design projects. SERC has selected its Capstone Marketplace Research Topics so that senior students will:

- Pursue subjects and problems of interest
- Experience limited system engineering techniques
- Find approaches and solutions of value to their government sponsors.

These sponsors, operational units and government research staff, will work directly with students. The web document, "[SERC Capstone Marketplace Objectives](#)" lists additional details on SERC's initiative.

[More information](#)

---

## 13. PPI AND CTI NEWS

---

## 13.1 Systems Engineering Tools Database Project News

The PPI-INCOSE team developing the online systems engineering tools database (SETDB) spent four intensive days on the project at the INCOSE International Workshop held in Torrance, CA over January 26-29, 2019. PPI was represented by PPI Managing Director Robert Halligan and PPI Senior Engineer René King. The team made major progress with requirements, architecture, project planning, and consultation with other stakeholders. Major future target milestones are:

- requirements release into development - February 2019
- database mockup (April 2019)
- substantial prototype for the INCOSE International Workshop Torrance 2020 (January 2020)
- Version 1 release INCOSE International Symposium Cape Town 2020 (July 2020).

Access will be free to PPI registered Systems Engineering Goldmine Users and to INCOSE members.

---

## 13.2 PPI Systems Engineering Goldmine Update

PPI will be undertaking a technical update of our [Systems Engineering Goldmine](#) through March and April 2019. The update will enable connectivity between the Goldmine and PPI collaborators. The Goldmine will be offline for about 24 hours in early April.

The Systems Engineering Goldmine is an online database of over 4GB of downloadable information relevant to the engineering of systems, and a searchable database of 7,800+ defined terms accessible by clients of Project Performance International (PPI) and Certification Training International (CTI). Limited access may be available to other users on a registration-approved basis only.

---

## 13.3 PPI Welcomes Paul Davies

PPI officially welcomes Mr Paul Davies, MA (Cantab), C.Eng, CSEP, MINCOSE, who joined our team as a Course Presenter and Principal Consultant. Paul will soon be conducting requirements-related training courses for PPI.

Paul has been actively presenting courses for our subsidiary company Certification Training International since 2017 both in the United Kingdom and beyond.

Based in the United Kingdom Paul has a wealth of diverse experience predominantly in the defence, aerospace, nuclear and rail industries and is renowned for successfully delivering challenging projects.

Paul supposedly retired in early 2014, but soon realised he needed to give something back to the systems engineering community and help mentor the next generation of practitioners. An experienced systems engineer, with thirty years in the defence and aerospace industry, six years in the nuclear industry, and a couple of years in rail, he has a wealth of diverse experience to call on. With a sound track record in delivering successful projects in the face of challenging customers, project managers and operational environments, Paul is a recognised authority on systems engineering.

A Cambridge graduate mathematician by training, Paul fell into systems engineering quite by accident. This started by building a solid background of engineering knowledge and physical processes underpinned by mathematical modelling and algorithm development. Later, he concentrated his interest in simulation, performance analysis, verification & validation, and requirements definition. By the age of 30, Paul had been given responsibility for several multi-million-dollar engineering projects. He has since gained enormous experience in all phases of project life cycles, specialising in early-stage requirements elicitation, interface and risk management, and stakeholder acceptance. In addition to applying systems engineering to high-tech projects, Paul has held functional management roles: in process improvement, in assessing individual and team competence, and in coaching and mentoring.

Before his retirement, Paul held the position of Discipline Manager for Systems Engineering at Network Rail Infrastructure Projects in the UK. He was primarily responsible for promoting improvements in process and standards, and in practitioner competence and training in all aspects of systems engineering, a relatively new concept to the rail industry. Prior to this, he worked for Thales UK for over 25 years, predominantly in electronic warfare and command and control systems. Subsequent to his project responsibilities, Paul managed the business unit innovations process and the supervision of university research, including the establishment of business cases and planning technology transfer. In parallel, he was a member of the corporate Systems Engineering Council, delivering continuous improvement in SE process and methods, and relevant training.

Paul has been a Visiting Professor at Loughborough University and a Visiting Fellow at Bristol University, and also a member of the *conseil d'administration* of the prestigious *Institut Supérieur de l'Aéronautique et de l'Espace* in Toulouse. He has acted as industrial supervisor for a number of PhD, Engineering Doctorate and Masters' students at five Universities in the United Kingdom.

He is a Past President of the INCOSE UK Chapter, in which role he founded its sponsoring Advisory Board and compiled its first entry into the INCOSE Chapters Awards, immediately winning a Gold Circle Award at the first attempt, and subsequently the President's Award for Outstanding Chapter. At international level, he has undertaken leadership roles on the Requirements Working Group and the SE Management Technical Committee, and as Outreach Director. He also acted as Master of Ceremonies at three INCOSE International Symposia. Paul's efforts for INCOSE were recognised by his being given the Founders' Award in 2015. Through an INCOSE UK initiative, he gained his Chartered Engineer title in 2012 through the IET, becoming one of the first fifty engineers to do so specifically in systems engineering.

Paul has conducted training courses and workshops in requirements, interface management, verification and validation, systems engineering management, competence assessment, and SE return on investment, with very positive feedback. He has been in constant demand for the presentation of courses and tutorials at many INCOSE events, both in the UK and internationally, winning several Best Paper and Presentation Awards. He has presented and coached in French and Spanish as well as English. With such a good alignment of aims, SE outlook, and commitment to excellence, Paul was delighted to join the Project Performance International/Certification Training International team in July 2017, as a Course Presenter.

Paul lives in Warwickshire, England, with his wife Carole. They have two adult children and two granddaughters. He counts among his interests, chess, keeping fit, pub quizzes, and of course, family.

We wish Paul every success and we are certain that he will be a great fit for the team. Welcome aboard Paul!

---

## 14. PPI AND CTI EVENTS

---

On-site systems engineering training is being delivered worldwide throughout the year. Below is an overview of public courses. For a full public training course schedule, please visit <https://www.ppi-int.com/course-schedule/>

### Systems Engineering 5-Day Courses

Upcoming locations include:

- Stellenbosch, South Africa (P006-771)

*01 Apr - 05 Apr 2019*

### Requirements Analysis and Specification Writing 5-Day Courses

Upcoming locations include:

- Bristol, United Kingdom (P007-479)

*10 Jun – 14 Jun 2019*

### Systems Engineering Management 5-Day Courses

Upcoming locations include:

- Munich, Germany (P1135-159)

*25 Feb – 1 Mar 2019*

- Melbourne, Australia (P1135-169)

*29 Apr – 3 May 2019*

### Systems Engineering Overview 3-Day Courses

Upcoming locations include:

- Las Vegas, Nevada, United States of America (P884-7)

*15 Apr – 17 Apr 2019*

### Requirements, OCD and CONOPS in Military Capability Development 5-Day Courses

Upcoming locations include:

- Melbourne, Australia (P958-57)

*04 Mar – 08 Mar 2019*

- Washington, D.C., United States of America (P958-59)

*13 May - 17 May 2019*

### **Engineering Successful Infrastructure Systems (ESIS5D)**

Upcoming locations include:

- Detroit, MI, United States of America (P2005-1)

*25 Mar – 29 Mar 2019*

### **Architectural Design 5-Day Course**

Upcoming locations include:

- Pretoria, South Africa (P1768-19)

*06 May - 10 May 2019*

### **CSEP Preparation 5-Day Courses** (Presented by Certification Training International, a PPI company)

Upcoming locations include:

- Bristol, United Kingdom (C002-91)

*04 Mar - 08 Mar 2019*

### **Medical Device Risk Management 3-Day Course**

Upcoming locations include:

- Berlin, Germany (P1848-3)

*18 Mar - 20 Mar 2019*

- Boston, MA, United States of America (P1838-2)

*09 Apr - 11 Apr 2019*

Other training courses available **on-site** only include:

- Project Risk and Opportunity Management 3-Day
- Managing Technical Projects 2-Day
- Integrated Product Teams 2-Day
- Software Engineering 5-Day

---

## **15. UPCOMING PPI PARTICIPATION IN PROFESSIONAL CONFERENCES**

---



PPI will be participating in the following upcoming events. We support the events that we are sponsoring and look forward to meeting old friends and making new friends at the events at which we will be exhibiting.

**Systems Engineering Test and Evaluation (SETE) Conference (SETE19) – Exhibiting**

Date: 29 April – 1 May, 2019

Location: Canberra, Australia

**The INCOSE International Symposium 2019 – Exhibiting**

Date: 20 – 25 July, 2019

Location: Orlando, USA

**EnergyTech Conference 2019 – Exhibiting**

Date: 21 – 24 October, 2019

Location: Cleveland, USA

**The INCOSE International Symposium 2020 – Exhibiting**

Date: 18 – 23 July, 2020

Location: Cape Town, South Africa

**Kind regards from the PPI SyEN team:**

**Robert Halligan, Editor-in-Chief, email: [rhalligan@ppi-int.com](mailto:rhalligan@ppi-int.com)**

**Ralph Young, Editor, email: [ryoung@ppi-int.com](mailto:ryoung@ppi-int.com)**

**René King, Managing Editor, email: [rking@ppi-int.com](mailto:rking@ppi-int.com)**

**Project Performance International**

2 Parkgate Drive, Ringwood, Vic 3134 Australia

Tel: +61 3 9876 7345

Fax: +61 3 9876 2664

Tel Brasil: +55 12 9 9780 3490

Tel UK: +44 20 3608 6754

Tel USA: +1 888 772 5174

Tel China: +86 188 5117 2867

Web: [www.ppi-int.com](http://www.ppi-int.com)

Email: [contact@ppi-int.com](mailto:contact@ppi-int.com)

Copyright 2012-2019 Project Performance (Australia) Pty Ltd, trading as  
Project Performance International

Tell us what you think of PPI SyEN. Email us at [syen@ppi-int.info](mailto:syen@ppi-int.info)