

Project Performance International

Systems Engineering

Newsletter (SyEN)

SyEN #028 - February 2, 2011

Brought to you by Project Performance International

<http://www.ppi-int.com/newsletter/SyEN-028.php>

Dear Colleague,

SyEN is an independent free newsletter containing informative reading for the technical project professional, with scores of news and other items summarizing developments in the field, including related industry, month by month. This newsletter and a newsletter archive are also available at www.ppi-int.com.

Systems engineering can be thought of as the problem-independent, and solution/technology-independent, principles and methods related to the successful engineering of systems, to meet stakeholder requirements and maximize value delivered to stakeholders in accordance with their values.

If you are presently receiving this newsletter from an associate, you may receive the newsletter directly in future by signing up for this free service of PPI, using the form at www.ppi-int.com. If you do not wish to receive future SE eNewsletters, please reply to the notifying e-mail with "Remove" in the subject line, from the same email address. Your removal will be confirmed, by email.

We hope that you find this newsletter to be informative and useful. Please tell us what you think. Email to: contact@ppi-int.com.

What's Inside:

[READ ALL](#)

A Quotation to Open On

Featured Articles - Body of Knowledge and Curriculum to Advance Systems Engineering (BKCASE)

... [READ MORE](#)

Systems Engineering News

- U.S. DoD Systems Engineering Research Center (SERC)
- U.S. Department of Defense Releases Systems 2020 Request For Information
- Upcoming Submission Deadlines and Themes for INSIGHT
- INCOSE Event Calendar
- Call for Papers for Theme Issues of Software and Systems Modeling
- Reliability and Maintainability Symposium Systems Engineering Panel
- Second Exam Level in Program to Certify Practitioners of Model-Based Systems Engineering Using SysML
- Comprehensive and Robust Requirements Engineering and Management Framework
- DoD Scales Back Conflict-of-interest Rules

... [READ MORE](#)

Featured Society - Complex Systems Society

... [READ MORE](#)

INCOSE Technical Operations - Space Systems Working Group

... [READ MORE](#)

Systems Engineering Software Tools News

- No Magic Releases Cameo Simulation Toolkit
... [READ MORE](#)

Systems Engineering Books, Reports, Articles and Papers

- Architecting Resilient Systems
- 10 Favorite Systems Thinking Books of the Past 10 Years (Or So)
- The Airspace as a Cognitive System
... [READ MORE](#)

Conferences and Meetings

... [READ MORE](#)

Education and Academia

- UCL Centre for Systems Engineering
- Postdoc Research Fellow Positions on System Analysis and Model Checking - Singapore University of Technology and Design
... [READ MORE](#)

Some Systems Engineering-Relevant Websites

... [READ MORE](#)

Standards and Guides

- ISO Technical Committees related to Systems Engineering
- ISO/IEC JTC 1 SC 7 - Software and System Engineering
... [READ MORE](#)

Some Definitions to Close On - User and Operator

... [READ MORE](#)

PPI News

- PPI Re-Introduces Project Risk Management Training
- Integrated Product Team Training Also Returns!
- New Faces at PPI
- PPI's Website Undergoes a Major Facelift
... [READ MORE](#)

PPI Events

... [READ MORE](#)

A Quotation to Open On

"High achievement always takes place in the framework of high expectation." - Charles F. Kettering (American engineer, inventor of the electric starter, 1876-1958)

Featured Articles

**Body of Knowledge and Curriculum to Advance Systems Engineering
(BKCASE)**

By Alwyn Smit (asmit@csir.co.za)

Background

In May 2007 the Integrated Systems and Software Engineering Curriculum (iSSEc) program begun at Stevens Institute of Technology, sponsored by the US DoD Director of Systems and Software. The project aimed to deliver three products, namely:

1. A modern reference curriculum for a master's degree in software engineering that integrates an appropriate amount of systems engineering (GSWE2009)
2. A modern reference curriculum for a master's degree in systems engineering that integrates an appropriate amount of software engineering (GRCSE)
3. A truly interdisciplinary degree that is neither systems not software engineering – it is both

Both Phase 1 and 2 conducted surveys to determine the current state of master's level education in their respective fields and both surveys showed the same general pattern in SwE and SE to be:

- Lack of consistency, structure and requirements in degree programs
- Several different types of degrees offered
- Lack of consistency in entrance expectations

What is BKCASE?

The Body of Knowledge and Curriculum to Advance Systems Engineering (BKCASE) project is the second phase of the iSSEc program and the December 2009 issue of INSIGHT [2] reported it was started in September 2009 by Stevens Institute of Technology, together with the Naval Postgraduate School. The project is a three-year effort to create:

1. A robust Systems Engineering Body of Knowledge (SE BoK)
2. A Graduate Reference Curriculum in System Engineering (GRCSE, pronounced "Gracie")

Endorsed by the INCOSE Board of Directors, with significant funding from the U.S. Department of Defense and support from the IEEE Systems Council, BKCASE is the response to a call from government and industry for a globally recognized, community-created foundation for the discipline of systems engineering. The BKCASE project hopes to materially influence standard practice, workforce models, certification, and graduate education around the world.

The BKCASE team includes invited authors and volunteer reviewers from around the world representing different locales, business segments, professional societies, and areas of expertise. The team has representation from government, industry and academia.

Two interim drafts and the final products were planned to be developed in one-year intervals starting in June (SE BoK) and September (GRCSE) of 2010, with version 1.0 products due out in 2012.

The BKCASE Project Charter

The BKCASE project charter is contained on the BKCASE website at <http://www.bkcase.org/about-bkcase/project-charter/>. The vision is defined as:

"Systems Engineering competency models, certification programs, textbooks, graduate programs, and related workforce development initiatives around the world align with BKCASE."

Besides the creation of the SEBoK and GRCSE products, the mission state the intent to facilitate the global alignment of related workforce development initiatives with SEBoK and GRCSE and the ultimate transfer of stewardship of SEBoK and GRCSE to INCOSE and the IEEE after BKCASE releases version 1.0 of those products. Possible integration into their certification, accreditation, and other workforce development and education initiatives is also envisaged.

What is the SEBoK?

The SEBoK was defined by Pyster and Olwell at the October 2010 NDIA Conference [5] as describing the boundaries, terminology, content and structure of SE that are needed to systematically and consistently support and enable:

1. Informing Practice
2. Informing Research
3. Defining Curricula
4. Certifying Professionals

5. Deciding Competencies

It is a guide to the literature, not all the content of the literature.

The SEBoK value proposition is defined in a presentation given by Art Pyster to the Finger Lakes Chapter of INCOSE in January 2010 [4].

What is in GRCSE?

The content of GRCSE was also defined by Pyster and Olwell at the October 2010 NDIA SE Conference [5] as:

1. Guidance for constructing and maintaining the reference curriculum
2. Entrance expectations
3. Objectives
4. Outcomes
5. Architecture
6. Core Body of Knowledge

GRCSE does not contain specific courses or specific packaging, but adaption and selective adoption is expected and encouraged.

The GRCSE value proposition is also defined in the presentation given by Art Pyster to the Finger Lakes Chapter of INCOSE in January 2010 [4].

The BKCASE Story

In a presentation made by Adcock, Lawson, Olwell, Pyster and Roussel at the EUSEC 2010 Academic Forum [3], the BKCASE project with all its interactions is depicted in the following systems diagram by Alice Squires. This diagram is in fact the culmination of the development of the “BKCASE Story” in both video and MS PowerPoint formats that can be found on the BKCASE website at <http://www.bkcase.org/about-bkcase/bkcase-story/>. The development of the systemigrams is also addressed in a paper by Squires, Pyster, Sauser, Olwell and Gelosh at the IS2010 [7].

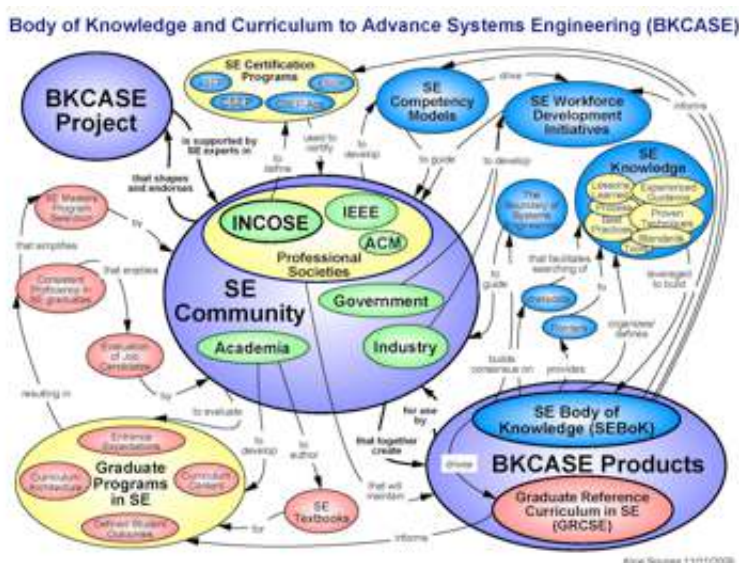

Pyster and Olwell concluded their presentation at the October 2010 NDIA SE Conference [5] by stating that:

“If the BKCASE project turns out to be successful, it is envisaged that:

1. The SEBoK will strongly influence the INCOSE SE Handbook Version 4, the INCOSE SE Professional Certification Program, UD DoD SE competency efforts, will highlight places where research is needed, become a standard reference for practitioners, and improve the quality and richness of communication among systems engineers worldwide.
2. GRCSE will clearly distinguish between graduate and undergraduate education in SE and influence the content of both undergraduate and graduate SE programs worldwide.”

Versions 0.25 of the SEBoK and GRCSE have both been released by Dec 2010 for limited review. These products have been the topic of some heated discussions in the INCOSE environment and to me that indicates the level of interest and passion that

surrounds the topic of SE education. This significant effort to unify and set a baseline for SE education is sure to elicit a lot more discussion before and after reaching public availability.

References:

1. N. Hutchison, M. Towhidnejad, G. Travassos, J. Brackett, R. Adcock, GRCSE and GSwE2009: Educational Advancements to Support Government and Industry, NDIA SE Conference, San Diego, California, Oct 2010, http://www.bkcase.org/fileadmin/bkcase/files/publications_and_briefs/NDIA_GSwE2009GRCSE_27Oct10_final.pdf
2. INCOSE INSIGHT, December 2009 - Volume 12 Issue 4, <https://connect.incose.org/INSIGHT%20Library/vol-12-issue-4.pdf>
3. Rick Adcock, Bud Lawson, Dave Olwell, Art Pyster, Jean Claude Roussel, BKCASE: Body of Knowledge and Curriculum to Advance Systems Engineering, Panel Discussion, 2010 EUSEC Academic Forum, Stockholm, http://www.bkcase.org/fileadmin/bkcase/files/publications_and_briefs/2010_EUSEC_Panel_on_BKCASE.ppt
4. Art Pyster, Global Workforce Development Initiatives in Systems and Software Engineering: BKCASE and GSwE2009, Presented to the Finger Lakes Chapter of INCOSE, 21 January 2010, http://www.bkcase.org/fileadmin/bkcase/files/publications_and_briefs/100121_BKCASE_and_GSwE2009_INCOSE_21Jan10.pdf
5. Art Pyster, Dave Olwell, The Body of Knowledge and Curriculum to Advance Systems Engineering Project, NDIA SE Conference, San Diego, California, Oct 2010, http://www.bkcase.org/fileadmin/bkcase/files/publications_and_briefs/NDIA_SE_Conference_October_2010.pdf
6. The BKCASE website, <http://www.bkcase.org>
7. Alice Squires, Art Pyster, Brian Sauser, David Olwell, Don Gelosh, Applying Systems Thinking via Systemigrams™ for Defining the Body of Knowledge and Curriculum to Advance Systems Engineering (BKCASE) Project, IS 2010, Chicago, Illinois, http://www.bkcase.org/fileadmin/bkcase/files/publications_and_briefs/2010INCOSESystemigramsBKCASESquires.pdf.

About Alwyn Smit

Alwyn is a systems engineer with the Council for Scientific and Industrial Research in South Africa. His career of 27 years includes more than 20 years in project management and systems engineering on defence related projects. He is a long standing member of INCOSE and a Certified Systems Engineering Professional. He is also a past president of the INCOSE SA Chapter and the editor of SyEN.

Systems Engineering News

U.S. DoD Systems Engineering Research Center (SERC)

Stevens Institute of Technology was awarded a five-year renewable contract by the National Security Agency (NSA), in conjunction with the Deputy Under Secretary of Defense for Acquisition and Technology (DUSD(A&T)), to establish the DoD Systems Engineering Research Center (SERC) at its Hoboken, New Jersey campus. This DoD University Affiliated Research Center (UARC) is focused on systems engineering research. The SERC was established to advance the practice of systems engineering within DoD by conducting innovative research into new SE methods, processes, and tools (MPTs) to address recurring problems in the acquisition of systems and services.

The SERC is responsible for systems engineering research that supports the development, integration, testing and sustainability of complex defense systems, enterprises and services. SERC will serve as the systems engineering research engine for the U.S. DoD and Intelligence Community (IC). Along with Stevens and the University of Southern California (USC) as its principal collaborator, researchers from 16 universities and research centers throughout the United States support the mission of SERC.

Dr. Dinesh Verma, dean, Stevens School of Systems and Enterprises, serves as executive director with Dr. Art Pyster, distinguished Stevens research professor, and Dr. Barry Boehm, professor of software engineering and director of the Center for Systems and Software Engineering at USC, serving as deputy executive director and director of research, respectively.

The mission of the SERC is to research and analyze advanced and emerging systems engineering practices and relevant technologies to address the full spectrum of U.S. DoD systems across the Department, from capability areas, enterprise systems, systems of systems, net-centric set of services, and interoperability down to subsystems and configuration items with the goal of ensuring consistency and systems engineering excellence throughout the acquisition life cycle.

While OSD and Component actions over the last four years have accomplished much to restore application of good systems engineering practices back into the way the U.S. Defense acquisition community does business, the U.S. DoD believes that much can still be accomplished to change root cause behaviors on these programs. Systems engineering research will inform the current state of practice on programs, provide a means to explore and exploit concepts to enable design and development

of complex systems, and underpin effective integration of program/business processes with technical management MPTs throughout the acquisition life cycle.

Recent research efforts are:

- System Security Engineering
- Evaluation of Systems Engineering Methods, Processes and Tools on Department of Defense and Intelligence Community Programs
- Investigation of a Graphical CONOPS Development Environment for Agile Systems Engineering
- Development of 3-Year Roadmap to Transform the Discipline of Systems Engineering

Additional information: <http://www.searc.org/research/research-publications/>

U.S. Department of Defense Releases Systems 2020 Request For Information

The Systems Engineering Directorate of the Defence Research and Engineering Directorate of the U.S. Department of Defense is leading the "System 2020" strategic initiative on behalf of the Office of the Director, Defense Research and Engineering, intending to fundamentally change the capabilities for the design, adaptation, and manufacture of defense systems.

DRE says that recent conflicts have highlighted the need for the U.S. DoD to be able to field capabilities and systems to respond rapidly to changing threats. The Department is exploring various approaches as alternatives to the typical practice of fielding systems that respond to specific point requirements that were defined years before the system's initial use. DRE says that current requirements-based systems tend to lead to "point solutions" designed to address specific threats, which in turn are assumed to evolve slowly in time. With the pace of events and agility of adversaries, systems of the future need to be far more flexible, adaptable to changing environments, without major redesign, large hardware replacements, or even major software code changes. Systems need to be modifiable or upgradable by reference to virtual models, by plug-replacing subcomponents, or installing new "apps," or upgrading hardware subsystems.

One approach of great interest is the use of engineering methods that enable the development of adaptable systems, supported with tools to enable rapid design changes and rapid fielding. Adaptable systems should be able to counter a broader range of threats and uncertain threat environments than today's defense systems.

To further this approach, the S-2020 initiative is designed to research, develop, and demonstrate engineering tools, technologies, and methods that facilitate the rapid design and manufacture of highly adaptable systems. This initiative is focused on a specific design methodology and a broad class of enabling tools that could make a significant contribution to adaptable system design and development. The design methodology is platform-based engineering (PBE), as defined below, and the entire suite of enabling tools and practices that are intended to foster platform-based engineering are identified as model-based engineering (MBE).

Platform-based engineering (PBE) is a design and development methodology that uses components and subsystems as building blocks in an enduring architectural framework to achieve desired functionalities across a broad range of product lines. The architectural framework provides a common core set of features, and the modular design allows for very rapid adaptation of a system to enable new capabilities and features. Further, subsystems should have utility across a number of product lines.

Model-based engineering (MBE) employs a model-based (vs. paper-based) approach to system design, capturing design choices and details, and executing the development of the system software and hardware. MBE enhances design reuse and speeds the implementation of design changes. Ideally, MBE allows one to integrate the design of electronics, software, physical structure, mechanical systems, connectors, cabling, hydraulics, and all significant components into a virtual realization of a complex system.

For further details, review this briefing presented at the 13th Annual NDIA Systems Engineering Conference, October 2010 and the following two reports:

- Systems-2020 Study Final Report. Booz Allen Hamilton, August 16, 2010
- Boehm, Barry, et al. Systems 2020 Strategic Initiative. DoD Systems Engineering Research Center Final Technical Report SERC-2010-TR-009, August 29, 2010.

For additional information, submission instructions, and to respond to the S-2020 Request For Information, Washington Headquarters Services RFI #HQ0034-RFI can be found on the Federal Business Opportunities website at <https://www.fbo.gov/index?s=opportunity&mode=form&id=ac172929742f12b6bb24ded547aed516&tab=core&tabmode=list&=>. Abstracts are due by noon, January 31, 2011.

Upcoming Submission Deadlines and Themes for INSIGHT

INSIGHT is the newsletter of International Council on Systems Engineering. It is published four times per year (January, April, July, October). INSIGHT features status and information about INCOSE's technical work, local chapters, and committees and boards. Additionally, related events, editorials, book reviews, trends, and how-to-do articles that are pertinent to the many aspects of a systems engineer's job are also included, as space permits.

[Upcoming submission deadlines and themes for INSIGHT](#)

INCOSE Event Calendar

International Workshop 2011 (IW 2011)	Jan 29 - Feb 01, 2011
Sixth International Conference on Systems Engineering sponsored by INCOSE-IL/ILTAM	Mar 08 - 09, 2011
CSER2011 - Ninth Annual Conference on Systems Engineering Research	Apr 14 - 16, 2011
SETE2011 The Systems Engineering Test and Evaluation Conference	May 02 - 04, 2011
21st Annual International Symposium	Jun 20 - 23, 2011
Second International Conference on Complex Systems Design and Management (CSDM 2011)	Dec 07 - 09, 2011

[More information](#)

Call for Papers for Theme Issues of Software and Systems Modeling

Theme Issue: Software and Systems Modeling with Graph Transformations

organized by Andy Schürr and Arend Rensink
(submission deadline: 03.04.2011)

Theme Issue: Models and Evolution

organized by Dalila Tamzalit, Dirk Derider, Bernhard Schätz, and Alfonso Pierantonio
(deadlines: intent to submit 10.01.2011; submission 15.03.2011)

[More information](#)

Reliability and Maintainability Symposium Systems Engineering Panel

Reliability and Maintainability Symposium, RAMS©, will present a powerful Systems Engineering Panel at the January 24-27 th, 2011 conference at Disney's Contemporary Resort, Lake Buena Vista, Florida.

[More information](#)

Second Exam Level in Program to Certify Practitioners of Model-Based Systems Engineering Using SysML

OMG® announced that "Model Builder-Fundamental," the second examination in the OMG Certified Systems Modeling Professional™ (OCSMP™) program, is now available. The program's sponsors IBM®, Lockheed Martin, Sparx Systems and No Magic, Inc., and OMG certification partner UML Technology Institute Co., Ltd. (UTI), have made construction and validation of the exams possible. For more information, please visit <http://www.omg.org/ocsmp>.

Comprehensive and Robust Requirements Engineering and Management Framework

Authored and designed by its Director Vijay S Shukla QBI Institute (<http://www.qbi.in>) has released a comprehensive and robust Requirements Engineering and Management Framework for the benefit of organizations and individuals including Requirement Engineers, Business Analysts, IT Business Analysts, Software Testers, Project Managers etc.

[More information](#)

DoD Scales Back Conflict-of-interest Rules

The US Defense Department is scaling back a tough, new conflict-of-interest rule for some contracts, including those for IT and professional services.

According to [a final rule](#), published in the Federal Register, only major weapons systems contracts and systems engineering and technical assistance will be subject to stricter standards.

[More information](#)

Featured Society

Complex Systems Society

The purpose of the Complex Systems Society (CSS) is to promote the development of all aspects of complex systems science in the countries of Europe, as well as the whole international scientific community.

The Society aims to promote complex systems research (pure and applied), assist and advise on problems of complex systems education, concern itself with the broader relations of complex systems to society, foster the interaction between complex systems scientists of different countries, establish a sense of identity amongst complexity scientists, and represent the complexity community at all international levels.

The Society was first launched at a European level on 7th Dec 2004 during The European Conference on Complex Systems at Foundation ISI in Torino, Italy. It became an international society in 2006 during the ECCS06 Conference in Oxford.

The Society is governed by a Council. Current President is Professor Jeffrey Johnson, Professor of Complexity Science and Design at the Open University, U.K. Other Officers are Vice-President and Treasurer, and Vice-President and Secretary. The Society is supported by a Secretariat based at the Open University. Thirteen Committees work on behalf of the Society.

The Society maintains a Complex Systems Registry, which presently lists 6254 scholars, 235 institutions and 123 laboratories worldwide. The website of the Complex Systems Society lists approximately 200 complex systems study projects underway worldwide.

Each year, the Complex Systems Society organizes a conference in a different country, publishing online proceedings. ECCS'10 - European Conference on Complex Systems, was held in Lisbon in September, 2010.

More information: <http://css.csregistry.org/tiki-index.php?page=HomePage>

INCOSE Technical Operations

Space Systems Working Group

<http://www.incose.org/practice/techactivities/wg/sswg/>

Charter

The Space Systems Working Group (SSWG) is an association of INCOSE members worldwide who are engaged in the practice of systems engineering in the space arena in government, academic and private industry organizations.

Leadership

Chair:
Steven Jenkins, Jet Propulsion Laboratory

Co-Chair:
Stephen Piggott, Canadian Space Agency

Communications Coordinator:
Marc Sarrel, Jet Propulsion Laboratory

Presentations

[Overview of SSWG - July 2006](#) Size: 400K

[2008 International Workshop Space Systems Summary Presentation](#) Size: 200K

Contact [Space Systems Working Group](#) for additional information or to join this group.

Background

At the INCOSE Workshop, held in Scottsdale, Arizona, in January 2000, an interest group was formed devoted to demonstrating the activities of systems engineering in the space industry, recognizing that many of the INCOSE members had careers in the space industry. This led to the initial creation of the Space Systems Interest Group on January 27, 2000.

The Charter for the INCOSE Space Systems Working Group (SSWG) was developed on April 28, 2000. The SSWG was voted by the Systems Engineering Applications Technical Committee (SEATC) Chairmen to be elevated from an Interest Group to a Working Group based on completion of the necessary elements cited in the Systems Engineering Organization Report. This vote was taken in a telcon on May 9, 2000.

Purpose

The purpose of the SSWG is to expand the body of knowledge of systems engineering as it is applied to space systems. Specifically, the purpose of the SSWG is to:

- Promote the use of systems engineering principles, techniques, and practices in a wide range of activities in the government, academic and private industry organizations which are identified with space applications;
- Share best practices in the international space arena;
- Link systems engineering organizations across international boundaries; and
- Promote the systems engineering principles within the member's home organizations.

Objectives

The chief means by which the SSWG accomplishes its purpose is through development and sponsoring of activities within the INCOSE during its symposia, workshops and its local chapters. The objectives include, but are not limited to, improving the people, processes, and resources used in the systems engineering mission as follows:

People

- Enunciating career opportunities for systems engineering in the space domain
- Recruiting qualified space systems engineers to membership
- Sponsoring professional programs at INCOSE meetings to exchange systems engineering techniques and practices used in the space domain
- Maintaining a forum within INCOSE to address space technology and applications issues
- Developing informational outreach programs to promote the successful application of the systems engineering approach within the space industry
- Representing INCOSE and the SSWG with other professional societies

Processes

- Developing analogies within the space community which might transfer to commercial and public interest applications
- Improving the systems engineering process within the space applications
- Reviewing and promulgating professional standards for the practice of systems engineering in space applications
- Maintaining a forum to exchange the successful practices and processes used in space applications
- Developing architectures for space exploration

Resources

- Maintaining a list of resources useful to systems engineers practicing in the space applications domain
- Identifying automated tools and their capabilities
- Facilitating interaction with other groups

Description

The application of systems engineering to the specific space subdomains offers challenging opportunities for discourse between other professions and the expansion of systems engineering within the space industry. Commercial and public interest applications have much to offer the traditional practices of systems engineering in the space industry, and systems engineering utilized in the space industry can be applied to a wide range of commercial and public interest applications with significant benefit.

Structure and Operation

The SSWG is composed of members of INCOSE who have interest in one or more of the systems engineering space subdomains cited previously. The policies and activities of the SSWG are governed by a board elected by the SSWG members at an annual symposium of INCOSE. Local working groups are elected or appointed from their local chapters. SSWG board consists of the following members:

- Chairperson, elected by the membership of the working group at the INCOSE annual symposium for a two-year term (The intent is to rotate the chair position among the international members)
- Deputy chair elected by the membership of the working group for a two-year term
- Secretary, selected by the chairperson for a two-year term

The responsibilities of the SSWG chairperson are as follows:

- Direct SSWG meetings
- Coordinate logistics for such meetings
- Ensure meeting minutes, agendas, and newsletters are prepared and distributed
- Establish the annual goals for the SSWG
- Prepare committee reports as required
- Interface with the INCOSE Technical Leadership Team (TLT) and other working groups
- Support coordination of the SSWG activities

The responsibilities of the SSWG deputy chair and secretary are assigned by the chairperson.

Membership

Persons who would like to participate in the INCOSE Space Systems Working Group should contact either the chairman or deputy chairman as listed on the INCOSE website.

Working Group Goals

The elected chairperson will set two-year goals for the working group. These goals will be set at the annual symposium and reflected in Appendix A of this document. The candidates for chair and deputy chair will submit their proposed goals at the annual symposium. These goals will be discussed and confirmed by the membership at the annual symposium. The goals of the SSWG are to:

- Contribute each year to the INCOSE annual international symposium
 - Review papers for the annual symposium.
 - Submit papers for the annual symposium.
 - Establish a space systems session and/or panel for the annual symposium.
 - contribute to IPAL in the area of space systems
- Contribute to the INSIGHT magazine
 - Create individual article(s) for an INSIGHT issue
 - Dedicate a complete issue of INSIGHT to space systems.
- Invite members to speak on how systems engineering is being performed in space systems applications within government, academia and private industry.
- Conduct outreach to academia in the area of space systems. Establish liaisons for student affairs at the universities.
- Generate white papers on important issues in systems engineering in the space domain.
- Serve as liaison to other space related organizations (e.g. AIAA, IEEE, AAS, etc.).

Published Products

- MBSE Grand Challenge Interim Report
 - MIT Graduate Class physics based model
 - Initial SSWG SysML based object oriented model
- IS'08 Panel Proposal
- Bibliography of Crosslink magazine articles on SE

Planned Work

- MBSE Grand Challenge
 - linking of models; added fidelity; development of state analysis SEM
 - December '08 Insight Issue
 - Gap Analysis - joint project w/Lean SEWG
-

Systems Engineering Software Tools News

No Magic Releases Cameo Simulation Toolkit

No Magic, Inc., claiming to be the leading global provider of integrated modeling, simulation & analysis solutions and services, announced the release of Cameo Simulation Toolkit, a ground-breaking extension to its award-winning modeling solution, MagicDraw. The Cameo Simulation Toolkit is the first in the industry to provide an extendable model execution framework based on Foundational Subset for Executable UML® Models (fUML) and State Chart XML (SCXML) standards.

[More information](#)

Systems Engineering Books, Reports, Articles and Papers

Architecting Resilient Systems

By [Scott Jackson](#)

The following two articles by Scott Jackson were published in the IIE Western Region News during December 2010:

Architecting Resilient Systems: Part 1 Accident Avoidance and Survival and Recovery from Disruptions – [More information](#)

Architecting Resilient Systems: Part 2 Accident Avoidance and Survival and Recovery from Disruptions - [More information](#)

10 Favorite Systems Thinking Books of the Past 10 Years (Or So)

by Janice Molloy

According to most sources, our current decade began on January 1, 2010, so I'm about a year late in compiling a list of my favorite systems thinking books of the 00s. But I've received so many requests lately for my systems thinking "must reads" that I've decided to run the risk of being hopelessly late to the party and share my top titles of the past 10 years (or so).

This list is admittedly U.S.-centric; please use the "Comments" section to recommend books published in other countries and from different perspectives on systems thinking. Another mea culpa is that I haven't included anything by Russell Ackoff. I hope you will weigh in with your suggestions on which of his books would make your top 10 greatest hits from the past decade.

[More information](#)

The Airspace as a Cognitive System

Dr. Gavan Lintern
Cognitive Systems Design, Melbourne, Australia

The theme for this special issue, the airspace as a cognitive system, stimulates these questions: What is a cognitive system and in what sense can we characterize the airspace as a cognitive system? I discuss these questions by reviewing ideas promoted in discussions of distributed cognition. I conclude that this notion of the airspace as a cognitive system offers considerable leverage for addressing the anticipated design challenges in airspace systems but that we need to avoid the distortions engendered by the pervasive techno-centric emphasis in systems design in favor of a human-focused emphasis that will aid development of robust and effective systems.

[Request a copy of this paper from Dr. Lintern](#)

Conferences and Meetings

RAMS - Reliability and Maintainability Symposium

January 24-27, 2011, Disney's Contemporary Resort in Lake Buena Vista, FL, USA

[More information](#)

ICECSE 2011 "International Conference on Electrical, Computer and Systems Engineering"

January 25-27, 2011, Dubai, United Arab Emirates

[More information](#)

INCOSE International Workshop 2011 (IW 2011)

January 29 - February 01, 2011, Hyatt Regency Phoenix, Phoenix, AZ, USA

[More information](#)

2011 Safety-critical Systems Symposium (SSS'11)

February 8-10, 2011, De Vere Grand Harbour Hotel, Southampton

[More information](#)

Workshop on Challenges and Opportunities for Lifeline Systems Engineering

February 9, 2011, San Diego, California

[More information](#)

Second International Conference on Exploring Services Sciences (IESS 1.1)

February 16-17-18, 2011, Geneva, Switzerland

[More information](#)

The Sixth International Conference on Systems Engineering in Israel

March 8-9 2011, Herzlia, Israel

[More information](#)

2011 International Conference on Systems Engineering and Modeling (ICSEM 2011)

March 11 to 13, 2011, Shanghai, Shanghai, China

[More information](#)

Second ACM/SPEC International Conference on Performance Engineering (ICPE 2011)

March 14-16, 2011 Karlsruhe, Germany

[More information](#)

Design, Automation & Test in Europe

March 14-18, 2011, Grenoble, France

[More information](#)

26th Symposium On Applied Computing

March 21 - 25, 2011, Tunghai University, TaiChung, Taiwan

[More information](#)

Requirements Engineering Track – 4th Edition

Part of the 26th ACM Symposium on Applied Computing

March 21 - 25, 2011, Tunghai University, TaiChung, Taiwan

[More information](#)

ICST Workshop on Requirements and Validation, Verification & Testing (ReVVerT 2011)

Co-located with the 4th International Conference on Software Testing, Verification and Validation (ICST 2011)

March 21-25, 2011 (one day), Berlin, Germany

[More information](#)

Scenario-Based Testing - SCENARIOS 2011 NEW

Co-located with the 4th International Conference on Software Testing, Verification and Validation (ICST 2011)

March 21, 2011, Berlin, Germany

[More information](#)

1st Int'l Workshop on Variability-intensive Systems Testing, Validation & Verification

Co-located with ICST 2011

March 21, 2011, Berlin, Germany

[More information](#)

7th Workshop on Advances in Model Based Testing (A-MOST 2011)

Co-located with the 4th International Conference on Software Testing, Verification and Validation (ICST 2011)

March 21, 2011 – Berlin, Germany

[More information](#)

IWEI 2011 - The International Working Conference on Enterprise Interoperability

March 22-24, 2011, Stockholm, Sweden

[More information](#)

MoBE-RTES 2011 - 2nd IEEE Workshop on Model-based Engineering for Real-Time Embedded Systems

March 28, 2011, Newport Beach, California

[More information](#)

REFSQ 2011 - 17th International Working Conference on Requirements Engineering: Foundation for Software Quality

March 28-30, 2011, Essen, Germany

[More information](#)

EPICAL - Workshop on Empirical Research in Requirements Engineering: Challenges and Solutions



March 31, 2011, Essen, Germany

[More information](#)

MBT 2011 - Seventh Workshop on Model-Based Testing

April 2-3, 2011, Saarbrücken, Germany

Satellite workshop of ETAPS 2011

[More information](#)

IEEE International Systems Conference

April 4-7, 2011, Montreal, Quebec, Canada

[More information](#)

Symposium on Theory of Modeling and Simulation (DEVS/TMS'11)

April 4-9 2011, Boston, MA, USA

[More information](#)

1st International Workshop on Model-driven Approaches for Simulation Engineering

Held under the aegis of the Symposium on Theory of Modeling and Simulation, part of the SCS SpringSim 2011 conference.

April 4-9, 2011, Boston, MA (USA)

[More information](#)

International Symposium on Ambient Intelligence

April 6-8, 2011, University of Salamanca, Salamanca, Spain

[More information](#)

Workshop on the Reliability of Intelligent Environments (WORIE '11)

within the [International Symposium on Ambient Intelligence](#)

April 6-10, 2011, University of Salamanca, Salamanca, Spain

[More information](#)

Systems Engineering & Architecting Doctoral Student Network (SEANET) workshop

In conjunction with the 9th Conference on Systems Engineering Research

April 14, 2011, University of Southern California, CA, USA

More information to follow

CSER 2011 - Conference on Systems Engineering Research

April 14-16 2011, Redondo Beach Crown Plaza, Redondo Beach, CA, USA

[More information](#)

17th International Conference on Information and Software Technologies

April 27th - 29th, 2011, Kaunas, Lithuania

[More information](#)

SETE 2011 – Systems Engineering and T&E

May 2-4, 2011, Rydges Lakeside, Canberra, Australia

[More information](#)

Software & Systems Engineering Essentials

May 9-10, 2011, Frankfurt, Germany

[More information](#)

Risk-Based Approaches to Major Decisions (Risk '11)

May 13 - 14, 2011, Falmouth, Cornwall, United Kingdom

[More information](#)

International Conference on Software and Systems Process (ICSSP 2011)

(co-located with ICSE 2011)

May 21-22, 2011, Waikiki, Honolulu, Hawaii, USA

[More information](#)

Sixth Workshop on SHaring and Reusing architectural Knowledge (SHARK 2011)

(co-located with 33rd Int. Conf. on Software Engineering (ICSE 2011))

May 21-28, 2011, Waikiki, Honolulu, Hawaii, USA

[More information](#)

RSP 2011 - IEEE International Symposium on Rapid System Prototyping

May 24 – 27, 2011, Karlsruhe Institute of Technology (KIT), Karlsruhe, Germany

[More information](#)

SPICE 2011 - The 11th International SPICE Conference Process Improvement and Capability dEtermination

30 May - 1 June 2011, Dublin, Ireland

[More information](#)

Seventh European Conference on Modelling Foundations and Applications

6-9th of June, 2011, University of Birmingham, Birmingham, UK

[More information](#)

TTCN 3 - 10th Testing & Test Control Notation User Conference

June 7-9, 2011, Bled, Slovenia

[More information](#)

4th Symposium on Resilience Engineering

June 8-10, 2011, Sophia Antipolis, France

[More information](#)

ONTOSE 2011 - 5th International Workshop on Ontology, Models, Conceptualization and Epistemology in Social, Artificial and Natural Systems

June 20, 2011, University of East London - Docklands Campus, London, UK

[More information](#)

BPMDS'11 Working Conference

in conjunction with CAISE 2011

June 20-21 in London, United Kingdom

[More information](#)

FM 2011: 17th International Symposium on Formal Methods

June 20 - 24, 2011, Lero, Limerick, Ireland

[More information](#)

The 32nd International Conference on Application and Theory of Petri Nets and Concurrency (PETRI NETS 2011)

11th International Conference on Application of Concurrency to System Design (ACSD 2011)

June 20-24, 2011 Kanazawa Cultural Hall, Kanazawa, Japan

[More information](#)

Swiss Requirements Day

June 22, 2011, Kongresshaus, Zurich

[More information](#)

INES 2011 - 15th IEEE International Conference on Intelligent Engineering Systems 2011

June 23-25, 2011, Poprad, High Tatras, Slovakia

[More information](#)

SoSE 2011 - 2011 6th International Conference on System of Systems Engineering (SoSE)

Jun 27 - 30, 2011, [Albuquerque](#), New Mexico, [U.S.A](#)

[More information](#)

ICMT2011 - International Conference on Model Transformation Theory and Practice of Model Transformations

Co-located with TOOLS Europe 2011
June 27 - July 1, 2011 - Zurich, Switzerland
[More information](#)

15th International Conference on System Design Languages

July 5th - 7th, 2011, Toulouse, France
[More information](#)

International System Dynamics Conference

July 24 – 28, 2011, Washington, DC, USA
[More information](#)

46th Annual International Logistics Conference and Exhibition (SOLE 2011)

August 2011
[More information](#)

19th IEEE International Requirements Engineering Conference

August 29 – September 2, 2011, Trento, Italy
[More information](#)

International Conference on Industrial Engineering, Systems Engineering and Engineering Management for Sustainable Global Development **NEW**

September 21-23, 2011, Spier Hotel and Conference Centre, Western Cape, South Africa
[More information](#)

Second Annual IIBA Conference

October 2011, More details TBA
[More information](#)

AGTIVE 2011 - International Symposium on Applications of Graph Transformation with Industrial Relevance **NEW**

October 4-7, 2011, Budapest, Hungary
[More information](#)

SSEE 2011 - Society for Sustainability and Environmental Engineering 2011 International Conference

October 24-26, 2011, Brisbane Convention & Exhibition Centre, Brisbane, Australia
[More information](#)

Education & Academia

UCL Centre for Systems Engineering

The University College London (UCL) Centre for Systems Engineering is a centre of excellence for Systems Engineering and the Management of Technology Projects.

It is their philosophy that the realisation of large, complex projects is a combination of good systems engineering practice, strategic planning, project management and systems thinking. In their courses they instill this multi-level, long term view of systems development so that the organisation undertaking such developments can be pro-active in dealing with the dynamics of the modern business environment.

[More information](#)

Postdoc Research Fellow Positions on System Analysis and Model Checking - Singapore University of Technology and Design

Highly motivated applicants are being sought to work on developing model checking techniques or applying model checking techniques to real-world problems. The postdoc will work with department of Information System Technology and Design, Singapore University of Technology and Design and collaborate with the software engineering team at National University of Singapore.

[More information](#)

Some Systems Engineering-Relevant Websites

<http://www.bkcase.org/>

BKCASE (pronounced "Bookcase") is the acronym for the Body of Knowledge and Curriculum to Advance Systems Engineering. The BKCASE project is led by a university partnership between the Stevens Institute of Technology and the Naval Postgraduate School. This site is intended to provide the public with information pertaining to the BKCASE mission and to serve as a project support tool for all BKCASE participants and advocates from around the world.

<http://graffletopia.com/stencils/146>

This webpage contains a stencil with all the major components for a Functional Flow Block Diagram (FFBD), which are used in developing the functional architecture of a system and describing the system's functional flow. The FFBD is also widely used in requirements analysis. The stencil is for use with OmniGraffle, a popular Mac. Drawing application.

<http://www.ap233.org/>

This portal is sponsored by PDES Inc. to support the AP233 development team. AP233 is a STEP-based data exchange standard targeted to support the needs of the systems engineering community, consistent with emerging standards in CAD, structural, electrical, engineering analysis and support domains. The AP233 Project is collaborating with the OMG SE DSIG team that is developing systems engineering extensions to Systems Modeling Language (OMG SysML™) and INCOSE (International Council on Systems Engineering), a systems engineering professional society. The site contains a wealth of systems engineering information.

<http://software-engineering142.blogspot.com/2009/05/development-of-ffbd.html>

This website provides a simple overview of the Functional Flow Block Diagram (FFBD). The archive contains several other overview pages of aspects of systems engineering.

Standards and Guides

ISO Technical Committees related to Systems Engineering

When viewing the list of ISO Technical Committees, it is clear that there are a host that has some relation to Systems Engineering. Some of these that are more directly related include:

- ISO/IEC JTC 1 SC 7 - Software and System Engineering
- ISO/IEC JTC 1/SC 35 - User interfaces
- ISO TC 159 – Ergonomics
- ISO TC 176 - Quality management and quality assurance
- ISO TC 184 - Automation systems and integration
- ISO TC 236 - Project Committee: Project Management
- ISO TMB/WG SR Technical Management Board/Risk management (ISO 31000)

We will be taking a closer look at each of them in the near future.

ISO/IEC JTC 1 SC 7 - Software and System Engineering

The [JTC1 SC 7 website](#) lists a host of information on this sub-committee. It includes a list of 16 working groups.

The [SC7 Business Plan for the JTC 1 Plenary, Belfast, UK, 2010-11-08 to 13](#) provides a management summary, a period review and the focus for next work.

The statement of scope, vision, purpose, area of work and core values is included in the management summary. The “Terms of Reference” of SC7 is quoted as “Standardization of processes, supporting tools and supporting technologies for the engineering of software products and systems.”

As part of the period review it provides this nice snapshot of the current collection of SC7 standards:

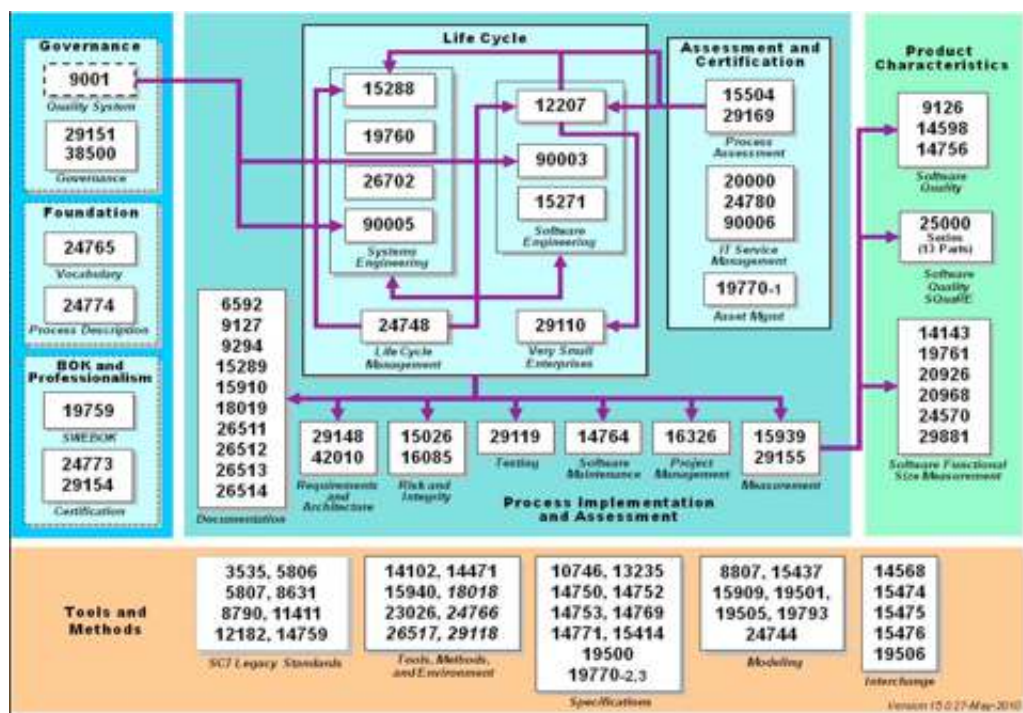

The [work programme](#) for ISO/IEC JTC 1 SC 7 is set out on the ISO website in terms of the standard or project, the [Standards Development Process Stage](#) code and the [International Classification for Standards](#) (ICS) reference.

[More information](#)

Some Definitions to Close On

User and Operator

User

User: A person or thing that uses something (stated or implied).

Source: <http://www.yourdictionary.com>

User: A user is any person that specifies Functional User Requirements and/or any person or thing that communicates or interacts with the software at any time.

Source: *IFPUG Glossary ISO/IEC 20926:2003(E)*

User: Individual who or group that benefits from a system during its utilization.

Source: *IEEE Std 1220-2005 IEEE Standard for Application and Management of the Systems Engineering Process*

User: Individual who or group, that benefits from a system during its utilization.

Source: *ISO/IEC 26702*

User: Individual or group that benefits from a system during its utilization.

Source: *CD 29148.2, Software and systems engineering - Life cycle processes Requirements engineering, 2010*

User: An operational command or agency that receives or will receive benefit from the acquired system.

Source: *DAU Glossary: Defense Acquisition Acronyms and Terms, 2009*

Operator

Operator: One who operates a machine or device

Source: <http://www.yourdictionary.com>

Operator: An individual or an organization that contributes to the functionality of a system and draws on knowledge, skills, and procedures to contribute the function.

Source: *IEEE Std 1220-2005 IEEE Standard for Application and Management of the Systems Engineering Process*

Operator: Entity that performs the operation of a system.

Source: *ISO/IEC 12207:2008 Systems and software engineering--Software life cycle processes*

Operator: In the context of Joint Capabilities Integration and Development System (JCIDS), an operational command or agency that employs the acquired system for the benefit of users. Operators may also be users. (JCIDS Manual)

Source: *DAU Glossary: Defense Acquisition Acronyms and Terms, 2009*

Project Performance International News

PPI Re-Introduces Project Risk Management Training

PPI has updated and re-introduced its popular 3-day Project Risk Management course, withdrawn in 2004 to make way for the longer Systems Engineering courses. The first new delivery will be in Sydney over 12-14 April, with subsequent deliveries during 2011 in Stellenbosch (South Africa), Auckland (New Zealand) and the Australian cities of Melbourne, Brisbane, Adelaide, Perth and Canberra. The course will be delivered by experienced Project Manager Clive Tudge, CEng MIET.

[More information](#)

Integrated Product Team Training Also Returns!

PPI's range of training in Integrated Product Teams has been re-introduced, in 1-day, 2-day, 3-day and 4-day plus facilitation forms. An Integrated Product Team (IPT) is a multi-disciplinary team with stakeholder participation, responsible, accountable and empowered to take a product from requirements through to successful supply, usually involving design and development. The team works on the basis of collaborative decision-making. Real IPTs have exhibited excellent performance in terms of product quality, cost and schedule.

[More information](#)

New Faces at PPI

The PPI Melbourne team has expanded, with the addition of Helen Hele and Elise Matthews. Helen is making her mark in course administration, whilst Elise will be helping spread the word regarding PPI's much-expanded range of courses for 2011.

PPI's Website Undergoes a Major Facelift

Coinciding with the release of many new courses, PPI's website has undergone major redevelopment. The home page is uncluttered and more direct. The user experience improvements include:

- addition of a new menu to the public courses menu item, requiring only a single user action to navigate to the description of any of PPI's public courses
- addition of "Closely Related Courses" sidebar list for each course, which makes relevant courses (including on-site only courses) easier to find
- addition of a region-based option for viewing course information, which allows you to look for relevant training in your area.

More information: www.ppi-int.com

Project Performance International Events

Systems Engineering 5-Day Course

Upcoming locations include:

- Stellenbosch, South Africa
- Sydney, Australia
- Amsterdam, The Netherlands
- London, UK
- Las Vegas, USA

[View 2010/2011 Systems Engineering Course Schedule](#)

Requirements Analysis and Specification Writing 5-Day Course

Upcoming locations include:

- Melbourne, Australia
- Adelaide, Australia
- Amsterdam, The Netherlands
- Stellenbosch, South Africa
- Las Vegas, USA

[View 2011 RA&SW Course Schedule](#)

OCD & CONOPS in Capability Development 5-Day Course

Upcoming locations include:

- Adelaide, Australia
- Pretoria, South Africa
- Canberra, Australia
- Brasilia, Brazil

[View 2011 OCD/CONOPS Course Schedule](#)

Software Development Principles & Processes 5-Day Course

Upcoming locations include:

- Amsterdam, The Netherlands
- Stellenbosch, South Africa
- Sydney, Australia

[View 2011 Software Development Principles & Processes Course Schedule](#)

Cognitive Systems Engineering 5-Day Course

Upcoming locations include:

- Melbourne, Australia
- Tokyo, Japan
- Las Vegas, USA
- Adelaide, Australia
- London, UK

[View 2010/2011 Cognitive Systems Engineering Course Schedule](#)

Requirements Engineering 5-Day Course

Upcoming locations include:

- São José dos Campos, Brazil

[View 2011 Requirements Engineering Course Schedule](#)

Introduction to Software Development Principles & Processes 2-Day Seminar

[View 2011 Introduction to Software Development Principles & Processes Seminar Schedule](#)

Introduction to Cognitive Systems Engineering

Upcoming locations include:

- Melbourne, Australia
- Sydney, Australia
- Singapore

[View 2011 Introduction to Cognitive Systems Engineering Seminar Schedule](#)

Introduction to Requirements Analysis 1-Day Seminar

Upcoming locations include:

- Brisbane, Australia
- Adelaide, Australia
- Melbourne, Australia

[View 2011 Introduction to Requirements Analysis Seminar Schedule](#)

Preparing Great Requirements Specifications 1-Day Seminar

Upcoming locations include:

- Brisbane, Australia
- Adelaide, Australia
- Melbourne, Australia

[View 2011 Preparing Great Requirements Specifications Seminar Schedule](#)

PPI Upcoming Participation in Professional Conferences

- SETE 2011 (Exhibiting)
 - INCOSE IS10 (Exhibiting)
 - MICSSA (Sponsor/Exhibiting)
-

Kind regards from the SyEN team:

Robert Halligan, Managing Editor, email: rhalligan@ppi-int.com

Alwyn Smit, Editor, email: asmit@ppi-int.com

Luke Simpson, Production, email: lsimpson@ppi-int.com

Project Performance International
PO Box 2385, Ringwood, Vic 3134 Australia
Tel: +61 3 9876 7345
Fax: +61 3 9876 2664
Web: www.ppi-int.com
Email: contact@ppi-int.com

Tell us what you think of SyEN: email to contact@ppi-int.com

If you do not wish to receive a copy monthly of SyEN in future, please reply to this e-mail with "Remove" in the subject line. All removals are acknowledged; you may wish to contact us if acknowledgement is not received within 7 days.

COPYRIGHT 2011 PROJECT PERFORMANCE (AUSTRALIA) PTY LTD, ABN 33 055 311 941. May only be copied and distributed in full, and with this Copyright Notice intact.