

Project Performance International

<http://www.ppi-int.com/newsletter/SyEN-035.php>

SYSTEMS ENGINEERING NEWSLETTER

brought to you by

Project Performance International (PPI)

SyEN 44 – June 5, 2012

Dear Colleague,

SyEN is an independent free newsletter containing informative reading for the technical project professional, with scores of news and other items summarizing developments in the field, including related industry, month by month. This newsletter and a newsletter archive are also available at www.ppi-int.com.

Systems engineering can be thought of as the problem-independent, and solution/technology-independent, principles and methods related to the successful engineering of systems, to meet stakeholder requirements and maximize value delivered to stakeholders in accordance with their values.

If you are presently receiving this newsletter from an associate, you may receive the newsletter directly in future by signing up for this free service of PPI, using the form at www.ppi-int.com. If you do not wish to receive future SE eNewsletters, please reply to the notifying e-mail with "Remove" in the subject line, from the same email address. Your removal will be confirmed, by email.

We hope that you find this newsletter to be informative and useful. Please tell us what you think. Email to: contact@ppi-int.com.

WHAT'S INSIDE:

Quotations to Open On

[Read More...](#)

Feature Article: Assessing System Readiness – Is It Ready for Prime Time?

[Read More...](#)

Systems Engineering News

- TASC Report: U.S. Defense Budget Austerity Calls for Renewed Emphasis on Systems Engineering and Integration
- INCOSE's UK Chapter is Developing a Series of Guides to Assist Systems Engineers
- Biggest FIRST(R) Robotics Championship Ever
- INCOSE Spain Chapter Informational Meeting in Madrid

[Read More...](#)

Ask Robert

What is the difference between a requirement and a specification?

[Read More...](#)

Featured Society – USC Center for Systems and Software Engineering (CSSE)

[Read More...](#)

INCOSE Technical Operations: Two New INCOSE Working Groups Have Been Started

- Future of Energy Working Group
- Systems Engineering – Project Management (SE – PM) Working Group

[Read More...](#)

Systems Engineering Tools News

- Additions to Requirements Management Tools List
- GoedelWorks Portal for System Engineering
- Siemens PLM Software Introduces Teamcenter 9
- Ryma Licenses Process Impact's Requirement Templates for FeaturePlan
- Product How-to: Taking control of requirements specification for smart energy embedded systems
- Rational Rhapsody Enlightenment Webinar Series
- Artisan Studio 7.4 Delivers All New Systems Simulation Plus Additional Modeling Features
- Constructive Cost Model for Software Intensive Systems-of-Systems (COSOSIMO)
- Vitech Corporation Releases A Primer for Model-Based Systems Engineering

[Read More...](#)

Systems Engineering Books, Reports, Articles, and Papers

- Systems Thinking and Systems Engineering
- Why New Systems Fail
- The Human and Organizational Causes of the Gulf of Mexico Blowout
- Systems Engineering, The Journal of INCOSE – Contents of the April 2012 Issue (Volume 15, Issue 1)

- INCOSE Insight – Contents of the April 2012 Issue
- Challenges in Complex Systems Science

[Read More...](#)

Conferences and Meetings

[Read More...](#)

Education and Academia

- One day seminar on Agile Project Management and Systems Engineering for Administrative, Technical, and Key Project Contributors
- Why the Nation Needs More Female Engineers
- Upcoming INCOSE-LA Speaker Meeting: "Can a 'Science' of Systems Contribute to Systems Engineering?"

[Read More...](#)

Some Systems Engineering-Relevant Websites

[Read More...](#)

Standards and Guides

- Requirements Interchange Format (ReqIF), Version 1.0.1
- Status of SysML 1.3
- Overview of Standards Published By by ISO/IEC JTC 1/SC7 Software and Systems Engineering

[Read More...](#)

Definitions to Close on – Complex and Complicated

[Read More...](#)

PPI News

[Read More...](#)

PPI Events

[Read More...](#)

Quotations to Open On

Life is about the contributions one can make to others.
--Judy Young

I am always doing things I can't do. That's how I get to do them.
--Pablo Picasso

Feature Article

Assessing System Readiness - Is it ready for prime time?

James W. Bilbro
JB Consulting International
jameswbilbro@jbconsultinginternational.com
www.jbconsultinginternational.com

Executive Summary

Developing systems that function properly in their operating environments can be a long and expensive process. This is true whether the system is a Personal Data Assistant (PDA) intended for use in the commercial sector or a satellite weather sensor in the public sector. The key to successful deployment and operation (i.e. within allocated cost and schedule) lies in the ability of the developer to accurately assess the likelihood of success at the earliest possible stage of the development process - preferably at the requirements stage before actual development begins. Accurate assessment in this context means a quantitative, not qualitative, assessment of the cost and schedule impacts of the risks associated with the development process. Arguably, the most significant risk to a development program (among those which can actually be controlled) is technical risk - particularly related to the maturity of the technology to be employed. It is the assessment of this risk from a systems perspective that this paper addresses.

Within the private sector, the system development process is typically aided by a tightly integrated process from R&D through product deployment. This is true even in the case where multiple companies are involved in the development, due to the fact that the profit motive (i.e. success or failure of the companies as well as the products) provides considerable incentive to the participants to make sure that such assessments are accurate. In spite of this incentive, frequent product recalls attest to the fact that such accuracy is often not the case. There are obviously many companies that have demonstrated phenomenal success in bringing products to market, and while the details of the assessment processes are closely held, they in all probability rely on a systematic process such as the stage gate process to be discussed later in this paper [Cooper, 2003].

Within the public sector, in general, there is a much looser connection between R&D and development. R&D and development are typically performed by different, often unconnected, and sometimes competing organizations from the private as well as the public sector. Although the profit motive may be alive and well within the individual private sector organizations, the absence of an overall profit motive within the public sector dominates the assessment process and makes it even more problematic. Within the U.S. public sector there have been many attempts over the years to simulate the profit motive and/or to develop various methodologies that would provide a more accurate assessment of the risks associated with a given development, which would lead to effective mitigations ensuring successful developments within allocated budgets and schedule. For the most part these have been unsuccessful.

This paper summarizes a number of methodologies developed for determining the readiness of a system to be taken into production, addressing both strengths and weaknesses. While the stage gate process used in many private sector organizations will be discussed in brief, the concentration will be on the myriad of methodologies developed and used in the public sector. These include: System Readiness Levels (SRLs); Technology Readiness Levels (TRLs); Integration Readiness Levels (IRLs); Risk Identification, Integration & 'ilities (RI3); Advancement Degree of Difficulty (AD2); and Systems Engineering Checklists (SEC). There are a number of possible permutations and combinations of these tools and processes that could be successfully employed to improve accuracy in determining system readiness, but there are a few key points that should be considered in the decision of which tools and processes to use:

- An integrated total system assessment approach should be used that addresses technology, manufacturing, integration, etc. from the system of systems level down to the individual component level;
- Current status should be augmented by a predictive assessment that addresses the combined risk, schedule, and cost to completion;
- While risk and cost assessments are currently undertaken, they are often only loosely connected to each other and often not at all to Technology Readiness Assessments;

- While risk and cost assessments are currently undertaken, they are often only loosely connected to each other and often not at all to Technology Readiness Assessments;
- Program risk assessments are typically qualitative in nature (e.g. the risk cube/matrix [NASA, 2007]) and therefore do not contribute substantively to the ability to determine the impact on program cost and schedule;
- Cost risk assessments, while quantitative in nature, typically do not take into consideration technical risks, or at best consider them to be implicitly accounted for, and thus do not adequately represent the cost and schedule impacts attributable to the technical risks;
- A system readiness process should be standardized through the use of tools – this facilitates independent assessments as well as comparisons between programs;
- The use of the tools and processes/methodologies selected should be mandatory: if they are not mandatory, they will may never be used and therefore never be improved. Program managers are already faced with so many demands that they will never voluntarily utilize yet another “helpful” process or tool;
- In the end, whatever approach is chosen, there needs to be a balance between “comprehensiveness” and ease of use. It is possible to generate 10,000 or more questions to cover everything imaginable; however, it is impractical from the point of view of the resources available to answer so many questions - and given the lack of omniscience among most engineers and program managers, they still are not likely to capture everything;

In summary, system readiness assessment must rely on the systems engineering process and be performed by the systems engineering community consistently, systematically and most important of all - quantitatively.

Introduction

As was stated in the Executive Summary, the following discussions will focus on methodologies developed for assessing systems developed for the public sector. This is not to say that the private sector could not benefit from incorporating various aspects of the tools and processes discussed - in the end, systematic, common sense approaches are applicable to both.

Within the U.S. federal government, program failures and cost and schedule overruns over the last two decades have made more urgent the need to focus on specific issues in order to improve performance. Initial focus was on Technology Readiness, soon to be followed by Manufacturing Readiness and, more recently, on a renewed emphasis on system engineering, including specifically, integration. In addition, there have been repeated acquisition reforms which also have led to little, if any, improvement. The most recent such reform has resulted in a significant roll-back of Technology Readiness Assessment (TRA) requirements. The impact of this roll-back is yet to be determined, but in all probability it is a fairly safe bet that future TRAs will be less likely to produce accurate assessments.

There is no question that attempts to use immature technology (both hardware and software) and lack of manufacturing capability have significantly contributed to the problems of cost and schedule overruns, as have integration issues, particularly in today's complex interrelated systems. However, it can be argued that all of these issues have arisen from failures in the system engineering process and, if a solution is to be found, it must be approached from a total system engineering perspective. A summary of tools and processes currently available follows.

Available Tools & Processes

Stage-Gate®

The Stage-Gate® process had its origins in a study of how companies bring their products to market - the answer being - not very well! [Cooper, 1976] The Stage-Gate® process relies on following a systematic approach to bringing products to market by breaking the process into phases, or stages. Each stage in the life cycle has a set of prescribed activities and is preceded by a gate that opens or closes the path to that stage depending upon a set of predetermined criteria. [Cooper, 2003] The concept is simple, the execution is not. It requires discipline, consistency, and rigor to be successful.

Technology Readiness Level (TRL)

Technology Readiness Levels (TRLs) originated in the late 1980's as a means of reducing schedule slips and cost overruns associated with using immature technology in NASA's programs [Sadin, et.al., 1989]. TRLs describe the phases in the technology development lifecycle and consequently can be considered as very similar to the Stage-Gate® process. Technology Readiness Assessment (TRA) uses TRLs to specify the maturity level of the technology being assessed. TRAs can (and arguably should) be performed on a system or even System of Systems basis as well as subsystem and component. This is particularly true in consideration of the fact that using legacy hardware or software in a new

system/environment frequently results in technology development. When a TRA is conducted at the system level all issues including integration are addressed. I.e., if a system level prototype is tested in a relevant environment, it must have been integrated first. Two tools exist for standardizing the TRA assessment – the AFRL TRL Calculator and the NASA-AFRL TRL Calculator. The latter calculator is specifically structured to perform assessments as a function of the program Work Breakdown Structure (WBS). It has 259 questions for the nine levels in three categories (hardware, software, and manufacturing). A web-based version of the AFRL TRL Calculator currently under development will also include a WBS capability.

The strength of the TRA approach (when used with a calculator tool) is that it provides a standardized means of making a comprehensive system assessment from the top down as well as from the bottom up. The weakness is that it only provides a status at the time of the assessment and does not address what is required for successful completion.

It should be noted that since April, 2011, the United States DoD uses TRLs as a helpful knowledge-based standard whereas previously the TRLs were required metrics. [TRA Guidance, 2011]

An International Standard on Technology Readiness Level Definitions and their criteria for assessment is under development. [Bilbro, et al, 2011]

Advancement Degree of Difficulty (AD2)

AD2 is designed to be done in conjunction with a Technology Readiness Assessment (TRA). The AD2 process is focused on determining the “tall tent pole” issues in cost, schedule, and risk that are associated with the various elements (systems, subsystems, components) deemed to be below the desired level of maturity by the TRA. It is structured around the Work Breakdown Structure (WBS) and asks a series of questions regarding the element under investigation concerning whether or not it can be designed, manufactured, tested, or operated. E.g., do you have the necessary models with the requisite accuracy and if not, what is the cost and schedule required to obtain them and what is the risk that they cannot be obtained? The results are portrayed in the form of identifying the weakest link, i.e., greatest risk, highest cost, longest time. AD2 is not intended as a replacement for a formal cost analysis nor risk analysis; rather it looks to provide quantified indicators for more detailed examination. The AD2 tool currently consists of 57 questions in 5 categories: Design & Analysis, Manufacturing, Software Development, Test, and Operations. Categories may be changed and questions may be changed or additional questions added. The strength of the AD2 process is that it is predictive and can (and should) be used from the system of system level down to the component level. The weakness is that it is only as good as the questions asked and they must be refined continually.

U.S. DOD Systems Engineering Checklists

There are 18 System Engineering Checklists covering all program phases intended to supplement the U.S. Armed Services' individual processes/methodologies. The TRA checklist for example consists of 69 questions in eight areas: Timing/Entry Level, Planning, Program Schedule, Program Risk Assessment, Critical Technologies Identification, TRA Panel, TRA Preparation and Event, and Completion/Exit Criteria. Each question is to be assessed with respect to risk categories of Red, Yellow, Green, Unassigned, or Not Applicable. The strength of the checklist approach as a whole is its comprehensiveness which, as was the case with the UK approach (below), is also one of its weaknesses because of the time required to apply it. The questions are also of a programmatic nature concerning whether or not a process has been completed without regard to how well it was done. The checklist approach also is only a status. While it does make a risk characterization, it does not provide any quantification of what remains to be done. It appears that while these checklists are recommended for DOD as a whole, only NavAir (the developer) makes much use of them.

Risk Identification, Integration, and 'ilities (RI3)

RI3 is a methodology designed to provide a concise set of questions that highlight key areas that have historically been overlooked, particularly in areas related to the integration of new technologies, and the “ilities.” It is intended to be used in conjunction with formal risk assessment processes, not as a replacement. It consists of 105 questions in nine categories: Design Maturity and Stability, Scalability & Complexity, Integratability, Testability, Software, Reliability, Maintainability, Human Factors, and People Organization and Skills. The questions are formulated in terms of “best practices” and if the answers are negative, the responder is asked to indicate a likelihood of the “best practice” not occurring and the subsequent consequence to the program. The results are captured in a conventional 5X5 risk matrix and in linearized likelihood and consequence charts. It is recommended that the linearized charts be used, due to the stigma associated with having “red” areas in a conventional 5X5 risk matrix which often results in risks being under reported. The strength of the RI3 methodology is that it is applicable to any level - from system of systems to components and that it focuses on issues that have most frequently been missed. The primary weakness of the RI3 method is that when the questions are examined, they are frequently dismissed as being common sense issues which “of course” are already being addressed. This can lead to the methodology being deemed unnecessary and therefore not utilized. Questions, of course, must

continue to be refined and if maximum benefit is to be achieved from the methodology, should be incorporated into formalized cost assessments.

System Readiness Level (SRL) (Stevens Institute, U.S.A.)

The SRL in this case is defined through the combination of the TRL of a given technology with the Integration Readiness Level (IRL) of each of the elements with which it will be integrated. The computation of SRL is considered as a normalized matrix of pair-wise comparisons of normalized TRL and IRL. The strength of this approach is that it recognizes that integration plays a major role in successful program completion and offers the opportunity to define a system readiness by a single number. One weakness of this approach is that representing a system readiness by a single number has the unwanted potential for masking major problems. A more limiting weakness is that it requires the use of Integration Readiness Levels which at this point are too ill-defined to result in practical application. This approach provides for status only and does not provide any means of quantifying what is left to be done. Substantial work remains to be done on quantifying IRLs if this methodology is to be successful.

System Readiness Level (SRL) (UK Ministry of Defense)

The UK MOD SRL methodology is an attempt to take a comprehensive look at all aspects of a program. It is used in conjunction with TRL assessments. The SRL self assessment tool has nine top level categories: System Engineering Drivers, Training, Safety & Environmental, Reliability & Maintainability, Human Factors, Software, Information Systems, Airworthiness, and Maritime. Each of these nine areas has a set of questions for each of the nine levels of the SRL for a total of 399 questions. Affirmative answers to a complete set of questions for a given level determines the SRL for that area. The composite SRL is displayed as a matrix of areas against individual SRLs, resulting in a particular signature at a given point in the program. The strength of this methodology is its comprehensiveness, which is also its major weakness: it is incredibly time consuming to perform this assessment and there has been some indication (not confirmed) that the UK MOD has discontinued use of this methodology. It is worth noting that the UK MOD attempted to utilize Integration Readiness Levels (IRLs) and Design Readiness Levels (DRLs) before settling on this approach.

Conclusion

Ensuring that a system is ready for prime time requires performing a quantitative assessment of the risks that are likely to be encountered in the development process. This starts with the identification of technical risks in the areas of technology maturity, software maturity, integration, etc. and continues with assigning cost and schedule impacts associated with making certain that those risks are sufficiently mitigated. This is in contrast to the current practice of using the risk cube in risk management plans. The risk cube is a management depiction that actually hinders true assessments by encouraging qualitative measures that in reality are of little use beyond making program managers feel good (whose programs never have any red areas by definition or by fiat.) I would like to suggest that the Systems Engineering community relegate the risk cube to a dark and dusty corner!

In summary, any of the tools and processes discussed in this paper can be combined and/or tailored to fit the needs of any organization, and their rigorous, systematic use can go a long way towards ensuring that a system is indeed ready for prime time!

Bibliography

Bilbro, James; Dennehy, Cornelius; Desai, Prasun; Holzer, Jenny; Kramer, Corinne; Nolte, William; Widman, Richard; Weinstein, Richard; "ISO TRL Definitions and Assessment Criteria - Status," 14th Annual Systems Engineering Conference Hyatt Regency Mission Bay - San Diego, CA October 24-27, 2011.

Cooper, Robert G., "Winning the new product game: an empirical study of successful product innovation in Canada," Montreal: Faculty of Management, McGill University, 1976.

Cooper, Dr. Robert G., "Winning at Product & Technology Innovation with Stage-Gate®," Copyright 2003 Product Development Institute, "Process for Assessing Technology Maturity and Determining Requirements for Successful Infusion into Programs, NASA Conference, Washington D.C., Sep 16-18, 2003. http://www.stage-gate.com/news_021003.php

NASA Systems Engineering Handbook, NASA/SP-2007-6105, Rev 1, 2007

Nolte, William L., Did I Ever Tell You About The Whale – Or Measuring Technology Maturity, Information Age Publishing, 2008.

Ramirez-Marquez, J.E.; Sauser, B.J., "System Development Planning via System Maturity Optimization," IEEE Transactions on Engineering Management, Vol. 56 Issue: 3 pp. 533 - 548 Aug. 2009

Sadin, Stanley T.; Povinelli, Frederick P.; Rosen, Robert, "NASA technology push towards future space mission systems," Space and Humanity Conference Bangalore, India, Selected Proceedings of the 39th International Astronautical Federation Congress, Astronautica, pp 73-77, V 20, 1989.

Web Resources

- AD2 Tool along with integrated TRL tool available at: <http://www.jbconsultinginternational.com>
- AFRL TRL Calculator is available at: <https://acc.dau.mil/Search.aspx?id=157372&m=6&tfp=1&tfk=1&tfd=1&q=trl>
- DOD Engineering Checklists are available at: <https://acc.dau.mil/CommunityBrowser.aspx?id=144143&lang=en-US>
- DoD Technology Readiness Assessment (TRA) Guidance April, 2011, revised 13 May 2011: <http://www.acq.osd.mil/ddre/publications/docs/TRA2011.pdf>
- Integrated TRL/AD2 Tool: <http://www.jbconsultinginternational.com>
- Manufacturing Readiness Level Deskbook: http://www.dodmri.com/MRL_Deskbook_V2.01.pdf
- Manufacturing Readiness Level Tool: <https://acc.dau.mil/CommunityBrowser.aspx?id=18231>
- NASA TRL Calculator: <https://acc.dau.mil/communitybrowser.aspx?id=25811>
- NASA TRL Descriptions (NASA Research and Technology Program and Project Management Requirements Appendix J) <http://nodis3.gsfc.nasa.gov/displayDir.cfm?t=NPR&c=7120&s=8>
- NASA Technology Readiness Assessment Process (NASA Systems Engineering Handbook (SP-6105), Appendix G) <http://education.ksc.nasa.gov/esmdspacegrant/Documents/NASA%20SP-2007-6105%20Rev%201%20Final%2031Dec2007.pdf>
- RI3 Tool and Guidebook are available at: <http://www.afit.edu/cse/page.cfm?page=164&sub=95>
- Stage-Gate® <http://www.stage-gate.com/>
- Stevens SRL Tool is under development at: <http://www.systemreadinesslevel.com/>
- UK MOD Tool is available at: <http://www.aof.mod.uk/aofcontent/tactical/techman/index.htm>

For more information:

JB Consulting International
 4017 Panorama Drive SE Huntsville, AL 35801
 Phone: 256-534-6245 Fax: 866-235-8953 Mobile: 256-655-6273 Skype: 256-513
 6625 E-mail: [jbc\(at\)knology.net](mailto:jbc(at)knology.net)
 Websites: <http://www.JBConsultingInternational.com>
<http://www.linkedin.com/in/jameswbilbro>

Systems Engineering News

TASC Report: U.S. Defense Budget Austerity Calls for Renewed Emphasis on Systems Engineering and Integration

A new report published by TASC, Inc. makes the case that systems engineering and integration (SE&I) is essential to manage United States defense budget constraints without jeopardizing national security, and that it would be a mistake to reduce funding for SE&I at the same time that national security programs in general are being reduced.

"Twenty-first century acquisition is more complex than national security acquisitions of the past. Today's systems need to

be more capable and agile than before, and they need to be built more quickly and at less cost," says Rich Rosenthal, Chief Technology Officer of TASC. "Engineering the big picture to accommodate these demanding requirements is the responsibility of systems engineering."

[More Information](#)

INCOSE's UK Chapter is Developing a Series of Guides to Assist Systems Engineers

Following the success of the Z Guides (see http://www.incoseonline.org.uk/Program_Files/Publications/zGuides.aspx?CatID=Publications), INCOSE UK has decided to develop a series of "How to Guides", called the Omega Guides, aimed at members, which provide guidance concerning how to use a variety of tools and techniques that can assist systems engineers in their day to day work. The first two of these guides are now available and a third is in production. If you would like to see an Omega guide on a particular topic or feel that you could help then please contact Hazel Woodcock (series editor) for more details.

[More information](#)

Biggest FIRST(R) Robotics Championship Ever

The FIRST Robotics Competition is an international high school robotics competition organized by FIRST (For Inspiration and Recognition of Science and Technology). Each year, teams of high school students compete to build robots weighing up to 54 kg (120 pounds), not including battery and bumpers, that can complete a task, which changes every year. Teams are given a standard set of parts and the game details at the beginning of January and are given six weeks to construct a competitive robot, that can operate autonomously as well as when guided by wireless controls, to accomplish the game's tasks.

The 2012 competition, the biggest FIRST Robotics Championship ever featured a U.S. National Basketball Association (NBA) Hall of Famer, a reigning World Series champion, a Pop Superstar, a Celebrity Chef, inventors, and Government officials.

An impressive 12,000 students from 32 countries and their robots compete in the championship, over April 25-28, 2012. Supporters included Avnet; the U.S. Central Intelligence Agency; the International Council on Systems Engineering (INCOSE); and the United States Army's Rapid Equipment Force.

Three teams from Stuart, FL., Mountain Home, AK, and North Brunswick, NJ won the final showdown, earning the coveted FIRST Robotics Competition Championship Winning Alliance. Several other U.S. and international FIRST student robotics teams earned honors for design excellence, competitive play, research, business plans, website design, teamwork, and partnerships. A not-for-profit organization founded in 1989 by inventor Dean Kamen, FIRST strives to inspire young people's interest and participation in science and technology.

More than 600 teams from 32 countries competed in the three levels of 2012 FIRST: FIRST(R) LEGO(R) League (FLL(R), grades 4 to 8, 9 to 14-year-olds in the U.S, Canada, and Mexico; 9 to 16-year-olds outside the U.S, Canada, and Mexico); FIRST(R) Tech Challenge (FTC(R), grades 9 to 12, 14 to 18-year-olds); and FIRST(R) Robotics Competition (FRC(R), grades 9 to 12, ages 14-18). In addition, 40 teams of 6 to 9-year-olds participated in the Junior FIRST(R) LEGO(R) League (Jr.FLL(R), grades K-3), showcasing their science and technology smarts in the Jr.FLL World Festival Expo.

In 2010, the 19th year of competition, 1,808 high school teams from Australia, Brazil, Canada, Turkey, the Netherlands, Israel, the United States, the United Kingdom, and Mexico were involved. In 2011, 2,075 teams participated in competitions in the United States, Canada, and Israel.

[More Information](#)

INCOSE Spain Chapter Informational Meeting in Madrid

The emerging Spain Chapter of INCOSE is organizing an informational meeting to be held in Madrid at the EOI, C/Gregorio del Amo 6, Madrid, on June 13, 2012. The meeting is open but registration is required.

[More information](#)

Ask Robert

Question: What is the difference between a requirement and a specification?

Answer:

In general, a requirement is an order, or demand, or imperative; something that someone requires, a need that must be met. In an engineering context, we have requirements concerning things to be engineered, giving us system requirements, software requirements, and requirements concerning other things. A system requirement, for example, is a characteristic of a system that any system solution is required to possess.

Requirements exist independently of their expression. When a requirement is written down in some language, it becomes a specified requirement.

When a set of specified requirements on a system, for example, is brought together, we have a requirements specification for that system (a system requirements specification). Many public domain and proprietary standards exist for system requirements specifications, software requirements specifications, interface requirements specifications, etc.

Design is solution description. When a specific record is made of design, we have a design specification.

In some industry sectors, for example medical, defense, and aerospace, the word “specification” is normally used to mean “requirements specification”. In other industry sectors, for example white-goods, or construction, the word “specification” is normally used to mean “design specification”. To avoid confusion and error, it is best to be explicit – that is, refer to requirements specification or design specification, as applicable.

Robert Halligan, FIE Aust

Featured Society

USC Center for Systems and Software Engineering (CSSE)

In June of 1993, The University of Southern California, U.S.A. (USC) Center for Software Engineering was founded In June of 1993 by Dr. Barry W. Boehm, to provide an environment for research and teaching in the areas of large-scale software design and development processes, generic and domain specific software architectures, software engineering tools and environments, cooperative system design, and the economics of software engineering. The Center took on the mantra of systems engineering in October, 2006.

The Center has established partnerships with leading U.S. public and private sector organizations through their participation in the CSSE's CSE General Affiliates' and COCOMO™ II Affiliates' programs. These organizations help fund the Center's research.

One of the main goals of the CSSE is to perform research and development of practical software technologies that can aid its Affiliate members in reducing cost, customizing designs, and improving design quality by doing concurrent software and systems engineering, while also meeting the requirements of the CSSE for research topics that will facilitate the training and education of skilled software leaders, armed with Ph.D. degrees.

Evidence of the Center's success in balancing its own academic needs and the needs of its Affiliates is the fact that, since it's founding in 1993, the Center has graduated at least 26 individuals with doctorates, while at the same time attracting the continued and on-going support of over two-dozen leading international industrial partners.

More recently, the CSSE has directed considerable effort towards System of Systems Engineering (SoSE).

System of systems (SoS) is a term used to describe a set of related net-centric, sometimes software-intensive systems that are used to provide capabilities that cannot be accomplished by any single system in the set. Each system that is part of an SoS is often referred to as a constituent system. In recent times, SoSs have become more complex and difficult to manage, due in part to the fact that SoS capabilities can conflict with single system requirements and plans and, for

systems that belong to more than one SoS, conflicts between the various SoSs' changes for a given constituent system.

Recent U.S. Department of Defense research has identified how engineering teams have adapted engineering activities to better manage and evolve SoSs. USC CSSE and the SERC SoS research to date has focused on:

- Analysis of SoS characteristics (USC-CSSE-2007-717)
- Analysis of Lead System Integrator (LSI) role (USC-CSSE-2007-725 and USC-CSSE-2008-803)
- SoSE incremental commitment and evolution (ICM .5 version)
- Comparison of SoSE management strategies (Lane dissertation)
- Cost model to support the estimation of SoSE effort (USC-CSSE-2007-716 and USC-CSSE-2009-503)
- Reference SoS to support SoSE research and analysis (CSCI 577b guest lecture for 4/14/2010)
- SoS SysML modeling to support SoSE (USC-CSSE-2010-506)
- Analysis of SoSE with respect to lean principles (USC-CSSE-2010-504)
- SoS test and evaluation (MIT PATFrame and USC-CSSE-2010-507)
- SoS engineering artifacts (USC-CSSE-2010-505).

Research continues in each of the above areas. In particular, CSSE is seeking industry partners to further refine and evolve the SoSE cost model. In addition, more recent U.S. DoD-lead research is analyzing SoSE artifacts developed and evolved during the various SoS engineering activities.

[More information](#)

INCOSE Technical Operations

Two New INCOSE Working Groups Have Been Formed

Future of Energy Working Group

Dr. Alex Pavlak is setting up a Future of Energy (FoE) working group. A paper he will be presenting at IS2012 in Rome this July describes the task, a classic concept definition phase. The proposed effort is unique in two respects. First it will focus on whole systems, the delivery of energy that is cheap safe sustainable and secure. Second it will focus on the destination, the long term goal. Given what is known today, what would post fossil fuel energy systems look like? The product will be technically feasible alternatives. Through publications and lectures, the FoE working group will raise public awareness of these factual constraints on social value choices. If you are interested in participating, please email Dr. Pavlak at alex(at)pavlak.net.

Systems Engineering – Project Management (SE – PM) Working Group

Dave Fadeley, ESEP, is forming a Systems Engineering - Project Management (SE - PM) Working Group with the intent of working with PMI Baltimore chapter members in order to enhance overall program success through the improved integration of practices between the two communities. At the international level, INCOSE and PMI have jointly released a statement in September 2011, "PMI and INCOSE Align to Help Organizations Improve Program Success" that outlines the partnership. They have also produced a white paper, "Toward a New Mindset: Bridging the Gap between Program Management and Systems Engineering". If you are interested in participating in this new working group, please send Mr. Fadeley an email at dbfadeley(at)verizon.net.

Systems Engineering Tools News

Additions to Requirements Management Tools List

ProR	http://eclipse.org/rmf/proj/	A RM tool that supports the ReqIF 1.0.1 Standard
Rally ALM	http://www.rallydev.com/platform-products/rally-editions	Includes RM for agile
CaseComplete	http://www.casecomplete.com	Includes RM for agile
Rational Requirements Composer	http://jazz.net/projects/rational-requirements-composer/	RM tool
SpiraTest	http://www.inflectra.com	Test mgmt with some RM

GoedelWorksPortal for System Engineering

Altreonic has announced the availability of GoedelWorks, an internet-based portal for safety and systems engineering. It is made available under a SaaS (Software As A Service) business model.

Based on a formalized approach, GoedelWorks is a technology platform for collaborative systems and safety engineering project delivery. Developed for use by global and distributed teams, GoedelWorks is designed to facilitate how people work together to build systems and products, making project delivery more collaborative, productive, and transparent. One can think of GoedelWorks as an extensible framework that dynamically integrates and synchronizes people, processes, and resources associated with systems engineering development projects. From very small chips to large networked systems, GoedelWorks is represented as a platform that facilitates teamwork and project management.

GoedelWorks aims in particular at safety engineering projects. Therefore, the platform supports not only the project development, but also the development of functional safety engineering processes, allowing them to integrate with the organization specific processes. Using a formalized approach, the team is guided from early requirements through final product release. Every change is recorded and project artifacts (such as those needed for safety certification) are created or updated while performing development.

A first functional safety engineering process flow is aimed at the automotive and related sectors. GoedelWorksIt achieves this by importing a generic process flow supporting standards including IEC61508, IEC62061, ISO26262, ISO13849, ISO25119, ISO15998, CMMI and automotive SPICE. The latter is the result of a joint project with Flanders Drive, a regional knowledge cluster in the automotive sector. Users can customize these processes and integrate their own processes. Once created, GoedelWorks acts like a wizard and on-line repository, recording any project change.

The GoedelWorks platform enables collaboration among all stakeholders, domain experts, and anyone who plays a role in the successful delivery of the system. A central repository keeps track of all dependencies and project artifacts.

The following graphic facilitates an understanding of the potential use of this tool:

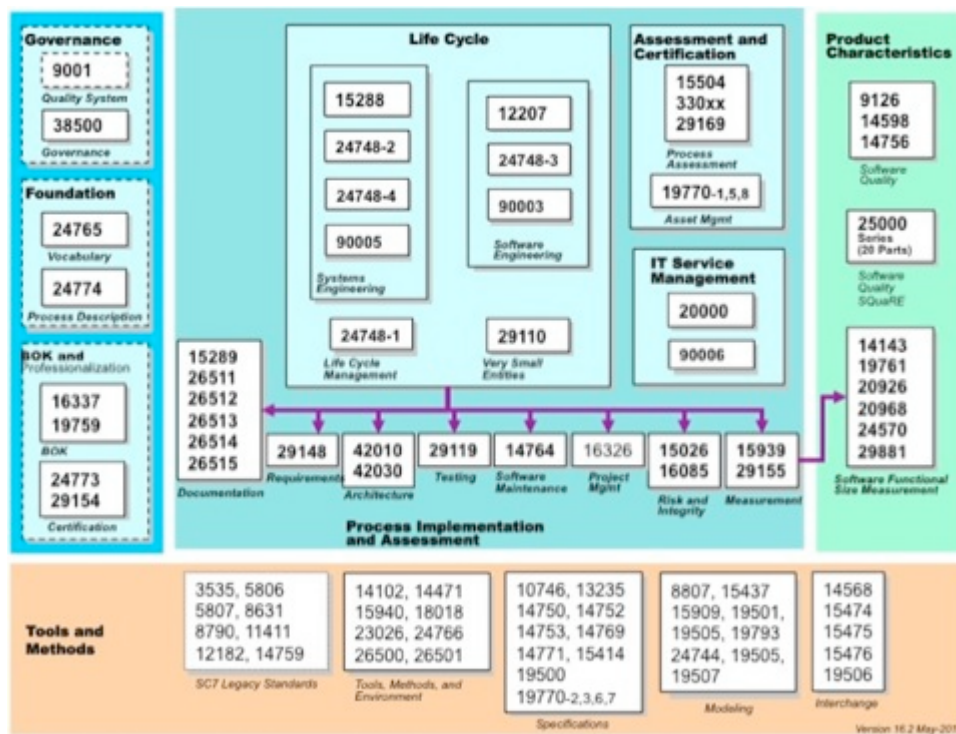

[More Information](#)

Siemens PLM Software Introduces Teamcenter 9

Siemens PLM Software, a business unit of the Siemens Industry Automation Division and a global provider of product lifecycle management (PLM) software and services, has announced the latest release of Teamcenter(R) software, a widely used PLM system. Teamcenter 9 delivers solutions and enhancements across the portfolio in support of Siemens PLM Software's HD-PLM vision, which was established to help companies make better informed decisions more efficiently and with a higher level of confidence. The Teamcenter 9 release adds a new integrated systems engineering solution and tightens the integration across the unified architecture so companies can make smarter decisions with better visibility into the impact of those decisions. Enhancements across the entire Teamcenter portfolio improve productivity and reduce the total cost of ownership.

[More Information](#)

Ryma Licenses Process Impact's Requirement Templates for FeaturePlan

Ryma Technology Solutions Inc., a company in product management solutions, has announced a partnership with Process Impact that will see the consultancy's requirements engineering templates integrated into Ryma's FeaturePlan product management solution. "Defining requirements is a critical step in product development that plays heavily on the success of any release," said Michel Besner, President and CEO of Ryma. "Through this partnership, customers from Ryma and Process Impact will be able to streamline the process of defining requirements by leveraging comprehensive templates that are integrated into FeaturePlan's Document Center module, allowing them to create comprehensive market and product requirements documents using analytics from the product database in a greatly reduced timeframe."

[More Information](#)

[Clive here to register for a webinar](#)

Product How-to: Taking control of requirements specification for smart energy embedded systems

Visure Solutions, a Spain-based company states that it plays a central role in the requirements context with its Requirements Engineering Lifecycle Solution, IRQA. IRQA is stated said to be a flexible requirements engineering lifecycle solution capable of streamlining requirements processes, allowing more effective collaboration, increasing quality,

supporting requirements capture, analysis, specification, validation and verification, management and reuse. More specifically, with IRQA, embedded systems developers is said to establish and enforce a requirements engineering process that everyone can follow in one single platform. They can engage all relevant stakeholders and achieve collaboration between them. Designers are also able to respond to changes, avoid pitfalls and mitigate risk every step of the way. Finally, they can improve quality through more effective change management and reuse, according to the company.

[More Information](#)

Rational Rhapsody Enlightenment Webinar Series

IBM is offering a series of free informational webinars on IBM Rational Rhapsody for systems engineering or embedded software development. The webinars are over the period June to December, 2012.

[More Information](#)

Artisan Studio 7.4 Delivers All New Systems Simulation Plus Additional Modeling Features

Atego™, a software tools and professional services supplier for complex, mission- and safety-critical systems and software engineering, has launched Artisan Studio 7.4, an important new version of its flagship model-driven development tool.

Emphasizing system level simulation, this release includes the optional add-on, Artisan Studio SySim. This new tool enables system engineers to find problems earlier in the design cycle when they are much cheaper to fix. Artisan Studio SySim augments OMG SysML models, making them executable, testable and verifiable. It allows systems engineers to visualize multi-scenario, complex system behavior and combines different execution engines. This first release of Artisan Studio SySim simulates and co-simulates behavior designs in Artisan Studio SysML, Atego Structured Action Language, VB.NET and Simulink.

"We are very pleased to announce the launch Artisan Studio 7.4, with its new and innovative approach to systems simulation," said Hedley Apperly, Atego's Vice-President of Product & Marketing. "Artisan Studio SySim's simulation of SysML models dramatically improves verification, leading to real reductions in overall project cost."

Artisan Studio 7.4 also incorporates a range of new capabilities including extensions to its IDL3/IDL3+ modeling & generation, model explorer auto-bookmarks, plus user interface enhancements for model versioning and the automation API. With Artisan Studio 7.4 you can now also reconcile sibling sandboxes, refactor state machines and difference the same package used in different models, according to Atego. Finally, the Artisan Studio Publisher now provides HTML package browser export.

[More Information](#)

Constructive Cost Model for Software Intensive Systems-of-Systems (COSOSIMO)

Efforts by the University of Southern California, U.S.A. (USC) Center for Systems and Software Engineering (CSSE) are underway to develop a Constructive Cost Model for Software Intensive Systems-of-Systems (COSOSIMO).

Today's need for more complex, more capable systems in a short timeframe is leading more organizations towards the integration of existing systems into network-centric, knowledge-based system-of-systems (SoS). Software and system cost model tools to date such as COSYSMO have focused on the software and system development activities of a single system. As CSSE views the new system-of-systems architectures, it finds that the System of Systems Engineering (SoSE) effort associated with the definition of the overall SoS architecture and then the integration of these system-components is not handled well, if at all, in current cost models. Efforts are currently underway to better understand SoSE effort and to use this information to develop a cost model, COSOSIMO, to estimate this effort.

[More Information](#)

Vitech Corporation Releases 'A Primer for Model-Based Systems Engineering'

David Long, president of Vitech Corporation, announced on May 22, 2012 the availability of the second edition of Vitech

Corporation's A Primer for Model-Based Systems Engineering, written by Long and co-author Zane Scott, Vitech's vice president of professional services. The book, ISBN #978-1-105-58810-5, is one of the model-based systems engineering (MBSE) references Vitech uses in its training courses and in the Vitech University Program. It is targeted to systems engineering practitioners working for government entities, for private and public companies, and for universities, or anyone interested in learning more about the basics of MBSE.

[More information](#)

Systems Engineering Books, Reports, Articles and Papers

Systems Thinking and Systems Engineering

College Publications

Series Co-editors: Harold "Bud" Lawson and Jon P. Wade

This series publishes books and proceedings that are related to Systems Thinking or Systems Engineering or both subjects. The series is a cooperative enterprise between College Publications and the School of Systems and Enterprises at Stevens Institute of Technology, USA.

Systems Thinking has grown during the 20th century into highly useful discipline independent theories and practices. Systems Thinking focuses upon understanding the holistic properties of complex systems and, in particular, the dynamic relationships that arise in the interactions of multiple systems in operation.

Systems Engineering has gained momentum during the latter part of the 20th century and has led to engineering related practices and standards that can be used in the life cycle management of complex systems. Systems Engineering focuses upon transforming the need for a system into a set of capabilities, requirements, functions or objects, that guides production of products and services that meet the need in an effective manner.

The combination of Systems Thinking and Systems Engineering is of particular interest in establishing the capability to "think" and "act" in terms of systems.



A Journey Through the Systems Landscape - Harold 'Bud' Lawson

Review from the publishers:

5.0 out of 5 stars A must read for systems engineering professionals and systems thinkers, March 9, 2012

We finally have a book on Systems Thinking that a systems engineer can relate to. Harold 'Bud' Lawson has written an exceptional book that provides a holistic view of the systems landscape.

The journey through the systems landscape exposes the paradoxes in the world of system development. The pursuit of solutions in response to problems and opportunities are often conflicted. Narrowly defined boundaries of a system, or problem, result in overly restrictive problem descriptions. Systems' thinking provides a practical framework for thinking outside these restrictive processes and to think and act in a holistic manner that is conscience of the extended system and its implications. Having a comprehensive view of complex system problems and opportunities is the single most important

transitional step towards building a learning organization that distinguishes itself from its competitors. We refer to this as systems thinking.

Lawson offers a practical rubric for incorporating Systems thinking into the organizational problem solving process. Systems' thinking fosters a holistic approach to problem solving which is attentive to all stakeholder needs that would otherwise go unnoticed and lead to unintended consequences. Lawson reminds the reader that organizations are themselves cybernetic systems. Enterprises use people, process, and tools to solve problems. How well these elements mesh are influenced by many interdependent factors that are easily overlooked and often lead to systematic shortfalls.

Lawson provides expert insights into the differences between Data, Information, Knowledge and Wisdom. The reader cannot help but be reminded of war stories where individual knowledge is not automatically understood at the team level. Lawson illustrates how Systems' thinking offers insight into building a learning organization that is equipped to deal with system complexity and the management of information in a changing environment.

I give the book an outstanding rating because it gives the reader a comprehensive overview of systems thinking and supporting literature to extend ones understanding of problem solutions and opportunities in the broader context of social systems.

Why New Systems Fail (Revised Edition)

Phil Simon

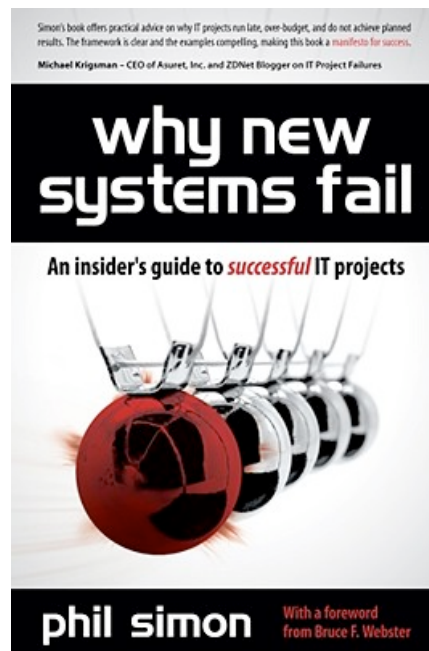

Published by: Course Technology, a part of Cengage Learning

ISBN: 978-1-4354-5644-0

Publication Date: February 23, 2010

Binding(s): Softcover

Abstract: (from Amazon.com)

A Fortune 500 manufacturing company spent millions attempting to implement a new enterprise resource planning (ERP) system. Across the globe, a 150-employee marketing firm built and tried to implement a proprietary customer relationship management (CRM) system. For two very different companies doing two very different things, the outcomes were identical. In each case, the organization failed to activate and utilize its system as initially conceived by senior management. And these two organizations are hardly alone. On the contrary, research indicates that more than three in five new IT projects fail. Many miss their deadlines. Others exceed their initial budgets, often by ghastly amounts. Even systems activated on time and under budget often fail to produce their expected results and almost immediately

experience major problems. Although the statistics are grim, there is at least some good news: these failures can be averted. Organizations often lack the necessary framework to minimize the chance of system failure before, during, and after beginning IT projects.

Why New Systems Fail provides such a framework, with specific tools, tips, and insight from the perspective of a seasoned, independent consultant with more than a decade of related experience. The book examines in great detail the root causes of system failures. Detailed case studies, examples, and lessons from actual system implementations are presented in an informative, straightforward, and very readable manner. More than a theoretical or technical text, this book offers pragmatic advice for organizations both deploying new systems and maintaining existing ones.

The book focuses on the largely neglected topic of buying and installing large, complex software packages from third-party vendors.

Editor's note: This book has a rating of 4.9 out of 5 stars based on reviews by 27 readers!

[More Information](#)

The Human and Organizational Causes of the Gulf of Mexico Blowout

Andrew Hopkins

Published by:
FutureMedia Pty Limited
3rd Floor
75 King Street
Sydney NSW 2000

[Ordering Information](#)

Publication Date: May 25, 2012

Abstract:

On 20 April 2010, a huge floating drilling rig, the Deepwater Horizon, had just completed drilling an ultra-deep well in the Gulf of Mexico when it suffered a blowout. The subsequent explosions and fire led to the loss of 11 lives, the sinking of the rig, and untold damage to the environment and to the livelihood of Gulf residents.

In this, his latest book – Disastrous Decisions: The Human and Organizational Causes of the Gulf of Mexico Blowout – leading disaster analyst, Professor Andrew Hopkins, takes the reader into the realm of human and organizational factors that contributed to this disaster, going beyond all previous commentary on this topic. He acknowledges that it is important to know what people did, but even more important to know why they did it.

The decision-makers invariably thought they were doing the right thing, when in fact their decisions were taking them, a step at a time, on a path to disaster. This book, therefore, attempts to “get inside the heads” of decision-makers and understand how they themselves understood the situations they were in. It also seeks to discover what it was in their organizational environment that encouraged them to think and act as they did.

Hopkins provides a sophisticated analysis of the accident that first identifies a series of critical defenses that failed and then goes on to explain why they failed. Disastrous Decisions: The Human and Organizational Causes of the Gulf of Mexico Blowout is an essential reference for all work, health and safety professionals.

Contents of the April 2012 Issue of Systems Engineering, The Journal of INCOSE

April 2012
Volume 15, Issue 1

Note: Access to INCOSE member resources and the searchable member directory is provided by using an INCOSE

Connect account that provides Collaboration Workspace for the INCOSE Community. See https://www.incose.org/cc_orders/joinINCOSE.cfm for information concerning how to access INCOSE Connect.

Requirements management within a full model-based engineering approach (pages 119–139)

Yves Bernard

Article first published online: 15 NOV 2011 | DOI: 10.1002/sys.20198

- Abstract
- Full Article (HTML)
- PDF(5735K)
- References
- Request Permissions

Constructing a general framework for systems engineering strategy (pages 140–152)

Clement Smartt and Susan Ferreira

Article first published online: 10 OCT 2011 | DOI: 10.1002/sys.20199

- Abstract
- Full Article (HTML)
- PDF(1683K)
- References
- Request Permissions

Sensitivity analysis for multi-attribute system selection problems in onshore Environmentally Friendly Drilling (EFD) (pages 153–171)

O.-Y. Yu, S. D. Guikema, J.-L. Briaud and D. Burnett

Article first published online: 15 NOV 2011 | DOI: 10.1002/sys.20200

- Abstract
- Full Article (HTML)
- PDF(3311K)
- References
- Request Permissions

An empirical methodology for human integration in the SE technical processes (pages 172–190)

Nicholas Hardman and John Colombi

Article first published online: 13 FEB 2012 | DOI: 10.1002/sys.20201

- Abstract
- Full Article (HTML)
- PDF(3079K)
- References
- Request Permissions

A systems framework for distance learning in engineering graduate programs (pages 191–202)

Adedeji B. Badiru and Rochelle R. Jones

Article first published online: 15 NOV 2011 | DOI: 10.1002/sys.20202

- [Abstract](#)
- [Full Article \(HTML\)](#)
- [PDF\(2351K\)](#)
- [References](#)
- [Request Permissions](#)

Overcoming barriers to transferring systems engineering practices into the rail sector (pages 203–212)

Bruce Elliott, Anne O'Neil, Clive Roberts, Felix Schmid and Ian Shannon

Article first published online: 15 NOV 2011 | DOI: 10.1002/sys.20203

- [Abstract](#)
- [Full Article \(HTML\)](#)
- [PDF\(1623K\)](#)
- [References](#)
- [Request Permissions](#)

Risk to cyberinfrastructure systems served by cloud computing technology as systems of systems (pages 213–224)

Yacov Y. Haimes and Clyde C. Chittister

Article first published online: 9 FEB 2012 | DOI: 10.1002/sys.20204

- [Abstract](#)
- [Full Article \(HTML\)](#)
- [PDF\(659K\)](#)
- [References](#)
- [Request Permissions](#)

System-Aware Cyber Security architecture (pages 225–240)

Rick A. Jones and Barry Horowitz

Article first published online: 13 FEB 2012 | DOI: 10.1002/sys.21206

- [Abstract](#)
- [Full Article \(HTML\)](#)
- [PDF\(1944K\)](#)
- [References](#)
- [Request Permissions](#)

INCOSE INSIGHT

INSIGHT is the newsletter of International Council on Systems Engineering. It is published four times per year (January, April, July, and October). INSIGHT features status and information about INCOSE's technical work, local chapters, and committees and boards. Additionally, related events, editorials, book reviews, trends, and how-to-do articles that are pertinent to the many aspects of a systems engineer's job are also included, as space permits.

The April 2012 Issue is available on INCOSE Connect at https://connect.incose.org/INSIGHT_Library/vol-15-issue-1.pdf

Following is the Table of Contents for this issue:

From the President
 Special Feature – Meet the INCOSE Authors
 Textbook Authorship: A Half-Century Overview by Wolt Fabrycky
 Forum
 Getting Past Face Value
 Technical Operations
 INCOSE Working-Group Awards Presented at the 2012 International Workshop 30
 Systems and Software Engineering Standards for Very Small Entities
 Papers and Posters for the 2012 International Symposium:
 A Great Variety of Topics
 Ontology and Systems Engineering
 INCOSE Operations
 INCOSE's Finances and Operations: Review of 2011
 INCOSE Certification Reaches a Milestone
 INCOSE Certification Agreements Signed
 INCOSE Events
 Green Growth and Systems Engineering in South Korea
 17th Annual Conference of the International Test and Evaluation Association
 Reflections from the 2012 International Workshop
 INCOSE Foundation
 INCOSE Spotlight
 In Memoriam William W. Schoening
 Book Reviews
 Final Thoughts

Challenges in Complex Systems Science

The Cornell University Library provides a paper of great interest and importance.

FuturICT foundations are social science, complex systems science, and ICT. The main concerns and challenges in the science of complex systems in the context of FuturICT are laid out in this paper with special emphasis on the Complex Systems route to Social Sciences. This include complex systems having: many heterogeneous interacting parts; multiple scales; complicated transition laws; unexpected or unpredicted emergence; sensitive dependence on initial conditions; path-dependent dynamics; networked hierarchical connectivities; interaction of autonomous agents; self-organisation; non-equilibrium dynamics; combinatorial explosion; adaptivity to changing environments; co-evolving subsystems; ill-defined boundaries; and multilevel dynamics. In this context, science is seen as the process of abstracting the dynamics of systems from data. This presents many challenges including: data gathering by large-scale experiment, participatory sensing and social computation, managing huge distributed dynamic and heterogeneous databases; moving from data to dynamical models, going beyond correlations to cause-effect relationships, understanding the relationship between simple and comprehensive models with appropriate choices of variables, ensemble modeling and data assimilation, modeling systems of systems of systems with many levels between micro and macro; and formulating new approaches to prediction, forecasting, and risk, especially in systems that can reflect on and change their behavior in response to predictions, and systems whose apparently predictable behavior is disrupted by apparently unpredictable rare or extreme events. These challenges are part of the FuturICT agenda.

The authors are Maxi San Miguel, Jeffrey H. Johnson, Janos Kertesz, Kimmo Kaski, Albert Díaz-Guilera, Robert S. MacKay, Vittorio Loreto, Peter Erdi, and Dirk Helbing

[More Information](#)

Conferences and Meetings

IBM Software Innovate 2012  **NEW**

June 3 – 7, 2012, Orlando, FL, USA

[More information](#)

SEPG Europe 2012

June 5 - 7, 2012, Madrid, Spain

[More information](#)

DASI Research Seminar: Cost Modelling for Systems Engineering

June 8, 2012, Mawson Lakes, South Australia

More information: nicole.durkay(at)unisa.edu.au

119th American Society for Engineering Education (ASEE) Annual Conference & Exposition

June 10 - 13, 2012, San Antonio, Texas, USA

[More information](#)

Kongsberg Systems Engineering Event (KSEE)

June 14-15, 2012, Høgskolen i Buskerud, Kongsberg, Norway

[More information](#)

The Third International Symposium on Engineering Systems - CESUN 2012

June 18 - 20, 2012, Delft, The Netherlands

[More information](#)

iFM2012 ABZ 2012 - Abstract State Machines

June 18 - 22, 2012, CNR Research Area of Pisa, Italy

[More information](#)

12th International School on Formal Methods for the Design of Computer, Communication and Software Systems: Model-Driven Engineering (SFM-12:MDE)

June 18 - 23, 2012, Bertinoro Italy

[More Information](#)

NDIA Systems Engineering Division 2-Day Seminar

June 21 - 22, 2012, Arlington, VA

[More information](#)

GfSE User Forum: MBSE in practice - challenges

June 22, 2012, Hamburg, Germany

[More information](#)

International Conference on Business Process Modeling, Development, and Support (BPMDS 2012), the 13th edition of the BPMDS series, held in Conjunction with Conference on Advanced Information Systems Engineering (CAiSE'12)

June 25 - 26 2012, Gdansk, Poland

[More information](#)

3rd IEEE Track on Collaborative Modeling and Simulation (COMETS 2012)

June 25 - 27, 2012, Toulouse, France

[More information](#)

EuroSPI 2012 Conference/19th EuroSPI Conference - European Systems and Software Process Improvement and Innovation

June 25 - 27, 2012, Vienna University of Technology, Austria

[More information](#)

PETRI NETS 2012 - 33rd International Conference on the Application and Theory of Petri Nets and Concurrency

June 25 - 29, 2012, Hamburg, Germany

[More information](#)

12th International Conference on Application of Concurrency to System Design (ACSD 2012)

June 27 - 29, 2012, Hamburg, Germany

[More Information](#)

Eighth European Conference on Modeling Foundations and Applications (ECMFA)  NEW

July 2 - 3, 2012, Technical University of Denmark (DTU), Kongens Lyngby, Denmark

[More information](#)**8th European Conference on Modelling Foundations and Applications**

July 2 - 5, 2012, Technical University of Denmark, Denmark

[More information](#)**The World Congress on Engineering 2012**

July 4 - 6, 2012, London, United Kingdom

[More information](#)**INCOSE International Symposium (IS) 2012**

July 9 - 12, 2012, Rome, Italy

IS2012 Call for Papers: Deadline for draft papers, and proposals for panels and tutorials for IS2012 is November 8th, 2011.

[More information](#)**Interdisciplinary Network for Group Research (INGRoup) - Seventh Annual Conference**

July 12 - 14, 2012, Chicago, IL, USA

[More information](#)**10th ACM/IEEE Conference on Formal Methods and Models for Co-Design (MEMOCODE 2012)**

July 16 - 17, 2012, Arlington, VA, USA

[More information](#)**IEEE SOSE 2012 7th International Conference on System of Systems Engineering**

July 16 - 19, 2012, Genoa, Italy

[More information](#)**International Conference of the System Dynamics Society, 2012**

July 22 - 26, 2012, St. Gallen, Switzerland

[More Information](#)**4th Improving Systems & Software Engineering Conference (ISSEC) 2012**

August 15 - 16, 2012, Melbourne, Australia

[More information](#)**KSE 2012  NEW**

August 17 - 19, 2012, Danang, Vietnam

[More information](#)**19th World Congress of the International Federation of Automatic Control (IFAC 2014)**

August 24 - 29, 2014, Cape Town, South Africa

[More information](#)**Workshop on Model-Driven Engineering for Networked Ambient System (MDE4NAS)**

August 27 - 29, 2012, Niagara Falls, Canada

[More information](#)**18th International Symposium on Formal Methods**

August 27 - 31, 2012, CNAM, Paris, France

[More information](#)**Sixth IEEE International Conference on Self-Adaptive and Self-Organizing Systems (SASO 2012)  NEW**

September 10 - 14, 2012, Lyon, France

[More information](#)**International Workshop on Enterprise Integration, Interoperability and Networking (EI2N'2012)**

September 12 - 13, 2012, Rome, Italy

[More information](#)

10th International Conference on Formal Modeling and Analysis of Timed Systems (FORMATS 2012)

September 18 - 20, 2012, London, United Kingdom

[More information](#)**12th International Workshop on Automated Verification of Critical Systems (AVoCS 2012)**

September 18 - 20, 2012, Otto-Friedrich University in Bamberg, Germany

[More information](#)**Risk Engineering Society Conference (RISK 2012)** 

September 20 – 22, 2012, Sydney, Australia

[More information](#)**RePa 2012 : Second International Workshop on Requirements Patterns**

September 24, 2012, Chicago, USA

[More information](#)**20th International Requirements Engineering Conference (RE 2012)**

September 24 - 28, 2012, Chicago, Illinois, USA

[More information](#)**SAFECOMP 2012**

September 25 – 28, 2012, Magdeburg, Germany

[More information](#)**MODELS 2012, ACM/IEEE 15th International Conference on Model-Driven Engineering Language & Systems - Call for Papers - Deadline 19 March 2012**

September 30 - October 5, 2012 – Innsbruck, Austria

[More Information](#)**6th INCOSE Annual Great Lakes Regional Conference 2012**

October 12 – 13, 2012, Schaumburg, Illinois, U.S.A

[More information](#)**World Engineering Education Forum (WEEF12)**

October 15 - 18, 2012, Buenos Aires, Argentina

[More information](#)**19th Working Conference on Reverse Engineering**

October 15 - 18, 2012, Kingston, Ontario, Canada

[More information](#)**Human Factors and Ergonomics Society HFES 2012 Annual Meeting**

October 22 - 26, 2012, Boston, MA, USA

[More information](#)**ICSSEA 2012**

October 23 - 25, 2012, Paris, France

[More information](#)**The World Congress on Engineering and Computer Science 2012**

October 24 - 26, 2012, San Francisco, USA

Building Business Capabilities (BBC) 2012

October 28 - November 2, 2012, Fort Lauderdale, FL, USA

[More information](#)**12th Annual CMMI Technology Conference and User Group**

November 5 – 8, 2012, Denver, USA

[More information](#)**INCOSE UK Annual Systems Engineering Conference 2012** 

November 7 - 8, 2012, London, UK

[More information](#)

Systems Engineering Day 2012 (TdSE 2012)

November 7 - 9, 2012, Paderborn, Heinz Nixdorf Museums Forum, Germany.

[More information](#)

14th International Conference on Formal Engineering Methods (ICFEM 2012)

November 12 - 16, 2012, Kyoto Research Park, Kyoto, Japan

[More information](#)

3rd International Conference on Complex Systems Design & Management (CSD&M 2012)

December 12 - 14, 2012, Cité Internationale Universitaire, Paris (France)

[More information](#)

INCOSE International Workshop IW2013

January 26 - 29, 2013, Jacksonville, Florida USA

[More information](#)

International Symposium on Engineering Secure Software and Systems (ESSoS) NEW

February 27 – March 3, 2013, Paris, France

[More information](#)

SysCon 2013 NEW

April 15 - 18, 2013, Orlando, FL, USA

[More information](#)

SETE 2013 NEW

April 29 – May 1, 2013, Canberra, ACT, Australia

12th International Symposium of the Analytic Hierarchy Process/Analytic Network Process (ISAHP 2013)

June 23 – 26, 2013, Kuala Lumpur, Malaysia

[More information](#)

APCOSE 2013 NEW

September 9 - 11, 2013, Keio University in Japan

[More information](#)

Education and Academia

Agile Project Management and Systems Engineering for Administrative, Technical, and Key Project Contributors

Agile is now used by over 80% of world-wide technology-intensive projects. This includes the U.S. DoD, Fortune 500 financial firms, global telecommunications industry, and Silicon Valley staples such as Google, Facebook, Yahoo, Amazon, Microsoft, etc. Agile project management and systems engineering is a highly-disciplined paradigm for developing high-risk, time-sensitive, technology intensive systems. It is a flexible and lightweight alternative to historical scope-driven paradigms such as the PMBoK and SEBoK, while simultaneously satisfying stringent quality and reliability performance objectives. A major goal of this seminar is to provide key decision-makers with the skills to plan, lead, and contribute to contemporary projects.

A one-day seminar jointly sponsored by INCOSE's Chesapeake Chapter and the Baltimore Chapter of the Project Management Institute (PMI) and led by Dr. Suzette Johnson and Dr. David F. Rico will be held on 2 June 2012 (8:00am – 4:30pm) at The University of Maryland Baltimore County (UMBC) Technology Center; 1450 South Rolling Road; Halethorpe, MD 21227 (USA).

[More Information](#)

[Registration](#)

Why the Nation Needs More Female Engineers – a view from the United States

The reasons young women shy away from engineering as a career include a lack of female engineering role models, having little knowledge of the solution-oriented work of engineers, and misconceptions about engineering being a “solitary” profession. Industry must step up its role in attracting young women to this exciting career where they can truly make a difference in people’s daily lives. We need more companies across divergent industries to help us promote engineering, create innovative K12 and university partnerships, and open their doors to interested students.

[More Information](#)

Comment by Robert: In my experience, approximately half of the engineers in Turkey are female. This is smart! Any nation which fails to utilize to the maximum the brainpower of half of its population would seem destined to pay a price accordingly.

Upcoming INCOSE-LA Speaker Meeting: "Can a 'Science' of Systems Contribute to Systems Engineering?"

SPEAKER: Dr. Len Troncale, Emeritus Professor of Biological Sciences, Director, Institute for Advanced Systems Studies, California State Polytechnic University, Pomona, CA

WHEN: Tuesday, June 12, 2012, 5:30 pm to 7:45 pm

WHERE: (RSVP required)

Booz Allen Hamilton – LAX Office

5220 Pacific Concourse Drive

Building 5220 - 2nd floor, Suite 200

Los Angeles CA 90045

Planned Remote Webcast Sites:

Available remote site locations will be listed on the INCOSE-LA website.

Contact site coordinator for information or directions.

RSVP/ Register online by Friday, June 8, 2012 at www.incose-la.org

Navigate to the web page for this event and click on the link for Registration.

Some Systems Engineering-Relevant Websites

<http://www.systemsengineeringblog.com/extreme-review-a-tale-of-nakedness-alsatians-and-fagan-inspection/>

This is a blog of Les Chambers, a true professional in the engineering of software- intensive systems. His article “Extreme Review: A Tale of Nakedness, Alsatians and Fagan Inspection” should be read by every graduate engineer.

<http://www.cs.uu.nl/wiki/bin/view/MethodEngineering/QUPERModel>

This wiki aims to provide the reader with an understanding of the QUPER model. The QUPER (QUality, PERformance) model was developed by Björn Regnell, Martin Höst and Richard Berntsson Svensson in 2007. The wiki starts from the research paper “Supporting Roadmapping of Quality Requirements” written by Björn Regnell, Richard Berntsson Svensson and Thomas Olsson. The method is described in detail, and then an example in which the method is applied is given. In the fourth section of the wiki, the process-deliverable diagram of the model is drawn and, lastly, related literature about the model is analyzed.

<http://www.jtc1-sc7.org/>

ISO/IEC JTC 1/SC7 Software and Systems Engineering has a new website, as of this May 2012. This is it.

Standards and Guides

Requirements Interchange Format (ReqIF) Version 1.0.1

The Requirements Interchange Format (ReqIF) defines an open, non-proprietary requirements exchange format. Requirement information is exchanged by transferring XML documents that comply to the ReqIF format.

A generic, nonproprietary format for requirements information is presented to satisfy the industry need for exchanging requirements information between different companies without losing the advantage of requirements management at the organizations' external interfaces.

[More information](#)

Status of SysML 1.3

SysML 1.3 is now expected to be released in June, 2012. The Beta 2 version is downloadable at <http://www.omg.org/spec/SysML/1.3/>

[More information](#)

Overview of Standards Published By ISO/IEC JTC 1/SC7 Software and Systems Engineering

The standards currently published by ISO/IEC JTC 1/SC7 - Software and systems engineering are summarized in the diagram below.

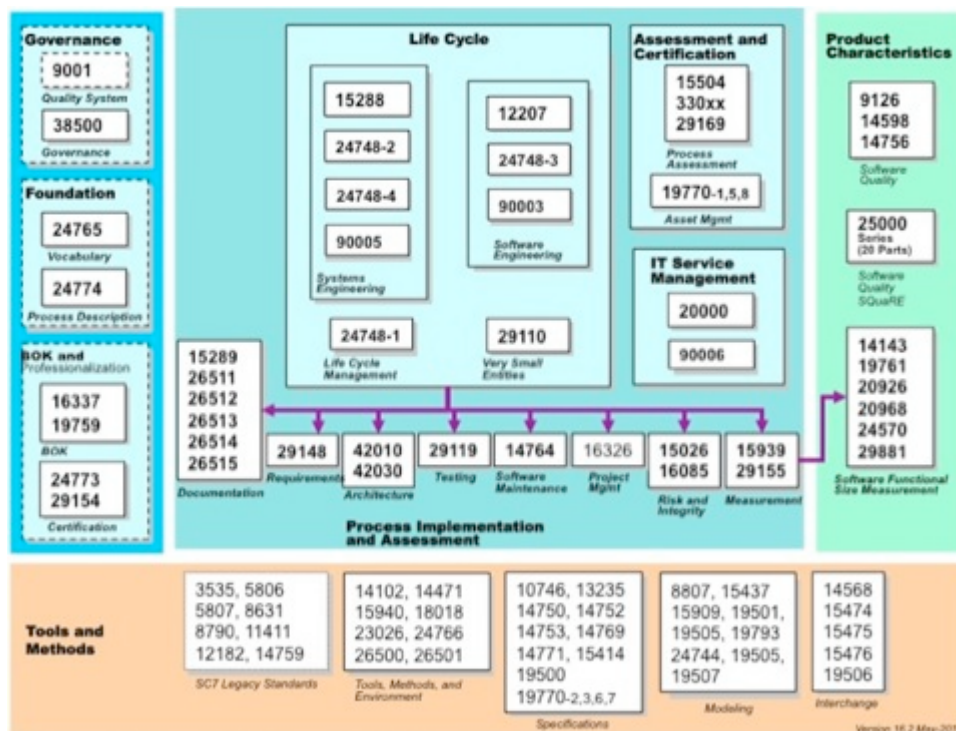

[More information](#)

Definitions to Close on

Complex and Complicated

Preface by Robert: You may have come across attempts in the systems engineering community to create a distinction between complex and complicated. Asked last week recently in Pretoria about the distinction, I replied that I do not make a distinction. Here's why.

Complex: composed of many interconnected parts; compound; composite: e.g. a complex highway system.
Source: Random House Dictionary

Complex: characterized by a very complicated or involved arrangement of parts, units, etc.: e.g. complex machinery.
Source: Random House Dictionary

Complex: So complicated or intricate as to be hard to understand or deal with: e.g. a complex problem.
Source: Random House Dictionary

Complex: made up of various interconnected parts; composite
Source: Collins English Dictionary

Complex: hard to separate, analyze or control
Source: Merriam-Webster English Dictionary

Complex: not easy to analyze or understand; complicated or intricate
Source: Compact Oxford English Dictionary

Complicated: containing intricately combined or involved parts. (Synonym: complex)
Source: American Heritage Dictionary of the English Language

Complicated: not easy to understand or analyze (synonym: complex)
Source: American Heritage Dictionary of the English Language

Complicated: made up of intricate parts or aspects that are difficult to understand or analyze (synonym: complex)
Source: Collins English Dictionary

Complicated: difficult to do, deal with, or understand, especially because of involving a lot of different processes or aspects
Source: Macmillan Dictionary

Complicated: consisting of many interconnecting parts or elements; intricate
Source: Compact Oxford English Dictionary

Complicated: containing parts intricately combined (synonym: complex)
Source: Merriam-Webster's Online Dictionary

PPI News (see www.ppi-int.com)

Robert Halligan Speaks in Pretoria, May 10, 2012: "Show me the evidence!"

Show me the evidence! Says the executive who is unconvinced about supporting systems engineering practices which all seem to involve additional up-front work at the expense of the project. The executive is sceptical, and so she should be! To permit major changes to the amount and balance of work without evidence of return on investment would be irresponsible.

The advocate of systems engineering, finding himself in this situation four years ago, was in serious trouble. Because scientific quality, compelling evidence of ROI for systems engineering did not exist. How the world has changed in four years!

In a standing-room only presentation to 80+ people on 10 May, 2012 in Pretoria. South Africa, Robert made the business

case for systems engineering as a tool for reduced costs, shorter timescales and increased product value delivery, embracing the results of a number of recent, soundly-conducted studies on the subject. The event, sponsored by INCOSE South Africa, took place at the Council for Scientific & Industrial Research (CSIR) campus east of Pretoria. A rumor that attendance was swelled by the wine tasting held afterwards is untrue!

Robert's presentation can be viewed as video at the INCOSE-SA website: <http://www.incose.org.za>

Within his travel schedule, Robert is pleased to support professional societies worldwide as a speaker, having already done so for IEEE (USA), SESA (Australia), KCOSE (South Korea), IIE (Australia), and many INCOSE Chapters worldwide – Finland, Netherlands, Germany, United Kingdom, Singapore, Sweden, South Africa, Italy, Turkey, Minneapolis, Las Vegas, amongst others.

Certification Training International Hits Washington

The INCOSE Certified Systems Engineering Professional (CSEP) training delivered by PPI subsidiary Certification Training International (CTI) has reached another milestone, with the first delivery by CTI of CSEP training in Washington, DC, USA during May 2012. Average course rating was 9.5; the median rating was 10! Pass rate for delegates who have taken CTI's training remains at 100%.

PPI Events (see www.ppi-int.com)

Systems Engineering Public 5-Day Courses

Upcoming Locations Include:

- Amsterdam, The Netherlands
- Adelaide, Australia
- Brisbane, Australia
- Rio de Janeiro, Brazil
- Munich, Germany

Requirements Analysis and Specification Writing Public Courses

Upcoming Locations Include:

- Melbourne, Australia
- Stellenbosch, South Africa
- Las Vegas, USA
- Amsterdam, The Netherlands

Software Engineering Public 5-Day Courses

Upcoming Locations Include:

- Sydney, Australia
- Pretoria, South Africa
- Amsterdam, The Netherlands

OCD/CONOPS Public Courses

Upcoming Locations Include:

- Brasilia, Brazil
- Pretoria, South Africa
- Las Vegas, USA

Cognitive Systems Engineering Courses

Upcoming Locations Include:

- Adelaide, Australia
- Las Vegas, USA

CSEP Preparation Course (Presented by PPI subsidiary Certification Training International)

Upcoming Locations Include:

- Las Vegas, USA
- Austin, USA
- Munich, Germany

PPI Upcoming Participation in Professional Conferences

PPI will be participating in the following upcoming events. We look forward to chatting with you there.

- ICOMS Asset Management Conference | Participating | Hobart, Australia (4 – 8 June 2012)
- INCOSE IS 2012 | Exhibiting | Rome, Italy (9 - 12 July, 2012)
- Land Warfare Conference 2012 | Exhibiting | Melbourne, Australia (22 - 26 October, 2012)

Kind regards from the SyEN team:

Robert Halligan, Managing Editor, email: rhalligan@ppi-int.com

Ralph Young, Editor, email: ryoung@ppi-int.com

Stephanie Halligan, Production, email: shalligan@ppi-int.com

Project Performance International

2 Parkgate Drive, Ringwood, Vic 3134 Australia

Tel: +61 3 9876 7345

Fax: +61 3 9876 2664

Tel Brasil: +55 11 3230 8256

Tel UK: +44 20 3286 1995

Tel USA: +1 888 772 5174

Web: www.ppi-int.com

Email: contact@ppi-int.com

Copyright 2012 Project Performance (Australia) Pty Ltd, trading as Project Performance International

Tell us what you think of SyEN: email to contact@ppi-int.com

If you do not wish to receive a copy monthly of SyEN in future, please reply to this e-mail with "Remove" in the subject line. All removals are acknowledged; you may wish to contact PPI if acknowledgement is not received within 7 days.

COPYRIGHT 2012 PROJECT PERFORMANCE (AUSTRALIA) PTY LTD, ABN 33 055 311 941. May only be copied and distributed in full, and with this Copyright Notice intact.